

Progress in quantum teleportation

Xiao-Min Hu^{1,2}, Yu Guo^{1,2}, Bi-Heng Liu^{1,2,3}✉, Chuan-Feng Li^{1,2,3}✉ & Guang-Can Guo^{1,2,3}

Abstract

Thirty years after it was first proposed, quantum teleportation remains one of the most important protocols in quantum information and quantum technologies, enabling the nonlocal transmission of an unknown quantum state. Quantum teleportation can be used to overcome the distance limitation in directly transferring quantum states in quantum communication and the difficulty in realizing long-range interactions among qubits in quantum computation. Since 2015, experimental quantum teleportation has moved from simple to complex quantum states (multiple degrees of freedom, high-dimensional quantum states) and from proof-of-principle demonstrations to real-world applications. We overview these advances, in particular, the understanding of the nonclassical nature of quantum teleportation, the teleportation of complex quantum states, progress in experiments with photons, atoms and solid-state systems and applications to quantum communication and computation, and discuss the challenges and opportunities for future developments.

Sections

Introduction

Theoretical progress

Quantum teleportation of complex quantum states

Quantum teleportation for quantum communication

Quantum teleportation for quantum computing

Outlook

¹CAS Key Laboratory of Quantum Information, University of Science and Technology of China, Hefei, China.

²CAS Center for Excellence in Quantum Information and Quantum Physics, University of Science and Technology of China, Hefei, China. ³Hefei National Laboratory, University of Science and Technology of China, Hefei, China.

✉e-mail: bhliu@ustc.edu.cn; cfl@ustc.edu.cn

Key points

- Quantum teleportation is the transfer of an unknown quantum state over long distances. This process requires entanglement and therefore cannot be simulated with classical channels.
- In practice, a single particle has many degrees of freedom, forming a complex quantum state. Quantum teleportation of such states requires more complex entanglement preparation and Bell-state measurements.
- Quantum teleportation is key for quantum communication technology. Long-distance quantum teleportation has been realized over a 100-km optical fibre channel and a 1,400-km satellite-to-ground free space channel, respectively.
- Quantum gate teleportation distributes local gate operations between spatially separated particles, so that it can be used to establish links among distributed quantum computing nodes in quantum networks.

Introduction

Human beings have long dreamt of being able to transport themselves, or objects, from one location to another without actually travelling in between. A technology achieving this dream was imagined in science fiction stories and was called ‘teleportation’. Three decades ago, a similar idea appeared in quantum information and was dubbed quantum teleportation. Quantum teleportation enables the reconstruction of an arbitrary unknown quantum state of a real particle at a different location without actually transmitting the particle. Unlike fiction, quantum teleportation has physical constraints: it requires entanglement¹ between the two locations and the transmission of classical information, which is limited by the speed of light.

Quantum teleportation was first proposed² in 1993 and in the early days, it was a theoretical scenario used in developing a formal theory of quantum information. But ever since, it has become an important concept in the now-established field of quantum information science³ and in quantum technologies, for example, in urban-scale quantum communication networks^{4–6} or noisy intermediate-scale quantum computing^{7–9}. The essential feature of quantum teleportation, that of enabling the nonlocal transfer unknown information, can be used to overcome the distance limitation in quantum communication and the difficulty in realizing long-range interactions in quantum computing.

Quantum teleportation was first demonstrated experimentally^{10,11} in 1997. Since then, scientists have performed quantum teleportation experiments in different quantum systems³ including photonic qubits (polarization and time bins), optical modes, NMR, atomic ensembles, trapped atoms and solid-state systems. These state-of-the-art experiments on quantum teleportation have been summarized elsewhere^{3,12}.

Over the past 8 years, two main trends have emerged in the development of quantum teleportation (Fig. 1) owing to the increasing control over large-scale quantum systems. First, there is great interest in teleporting complex quantum states such as photons with information encoded in high dimensions^{13,14} or in multiple degrees of freedom (DoFs)¹⁵, marking an important step towards the ultimate goal of teleporting all the information of a quantum system (Fig. 1a,d). Second, quantum teleportation has moved from the proof-of-principle demonstrations to practical applications. Great progress has been achieved in constructing long-distance quantum communication

networks using remote quantum teleportation based on near-Earth satellites¹⁶ and metropolitan optical fibre networks^{17,18} (Fig. 1b,e). Researchers have also laid the foundation for distributed quantum computing^{19–21} by demonstrating quantum teleportation of controlled gates in superconducting qubits²², trapped ions²³ and single neutral-atom quantum electrodynamics (QED) cavities²⁴ (Fig. 1c,f).

In this Review, we discuss the progress in quantum teleportation since 2015 and discuss the remaining challenges and future opportunities. We begin by introducing the theoretical progress, focusing on the new understanding of the nonclassical nature of quantum teleportation^{25,26} and some potential applications based on quantum teleportation. Next, we overview quantum teleportation of complex quantum states, focusing on multiple DoFs¹⁵ and high-dimensional^{13,14} systems. We then outline the development of teleportation in quantum communication^{16–18,27} and quantum computing^{22–24,28}. Finally, we highlight future challenges and opportunities for quantum teleportation, hoping that ideas from recent experiments will provide new inspiration for the rapid development of quantum technologies.

Theoretical progress

In quantum teleportation, an unknown quantum state is transmitted from one location, usually referred to as the sender, Alice to another, the receiver, Bob. It is necessary to establish two channels between Alice and Bob, a quantum channel and a classical channel. In Fig. 1a, we take the simplest qubit system as an example to introduce the basic protocol of quantum teleportation². The quantum channel consists of an entangled pair shared between Alice and Bob,

$$|\Psi^-\rangle_{23} = \frac{1}{\sqrt{2}}(|0\rangle_2|1\rangle_3 - |1\rangle_2|0\rangle_3), \quad (1)$$

which is one of the four maximally entangled Bell states ($|\Psi^\pm\rangle = \frac{1}{\sqrt{2}}(|0\rangle|1\rangle \pm |1\rangle|0\rangle)$ and $|\Phi^\pm\rangle = \frac{1}{\sqrt{2}}(|0\rangle|0\rangle \pm |1\rangle|1\rangle)$). Alice and Bob share this entangled state, in which particle 2 is with Alice and particle 3 is with Bob. Another party, called Charlie, provides the input particle 1 to be teleported to Bob in a general quantum state

$$|\Psi_A\rangle = \alpha|0\rangle_1 + \beta|1\rangle_1, \quad (2)$$

in which α and β are complex coefficients that satisfy $|\alpha|^2 + |\beta|^2 = 1$, unknown to both Alice and Bob. Then Alice performs a Bell-state measurement (BSM)^{29–31} and randomly projects particles 1 and 2 each to one of the four Bell states with equal probability. Finally, Alice informs Bob of the BSM result through the classical channel, and Bob performs the corresponding Pauli or combinations of operators $\{I, X, Z, ZX\}$ on his particle according to the results to recover the unknown quantum state $|\Psi_A\rangle$ of the particle of Charlie.

As an important protocol in quantum information, a basic framework for quantum teleportation was established and then many variants have been developed, such as quantum entanglement swapping⁵, gate teleportation³², port-based teleportation³³ and quantum teleportation networks^{34,35}. Recent theoretical advances in quantum teleportation focus on understanding its nonclassical nature and its potential applications.

Nonclassical teleportation

Quantum entanglement is key to realizing lossless transmission of unknown quantum states in quantum teleportation. In the ideal teleportation scheme, the fidelity between the input and output states

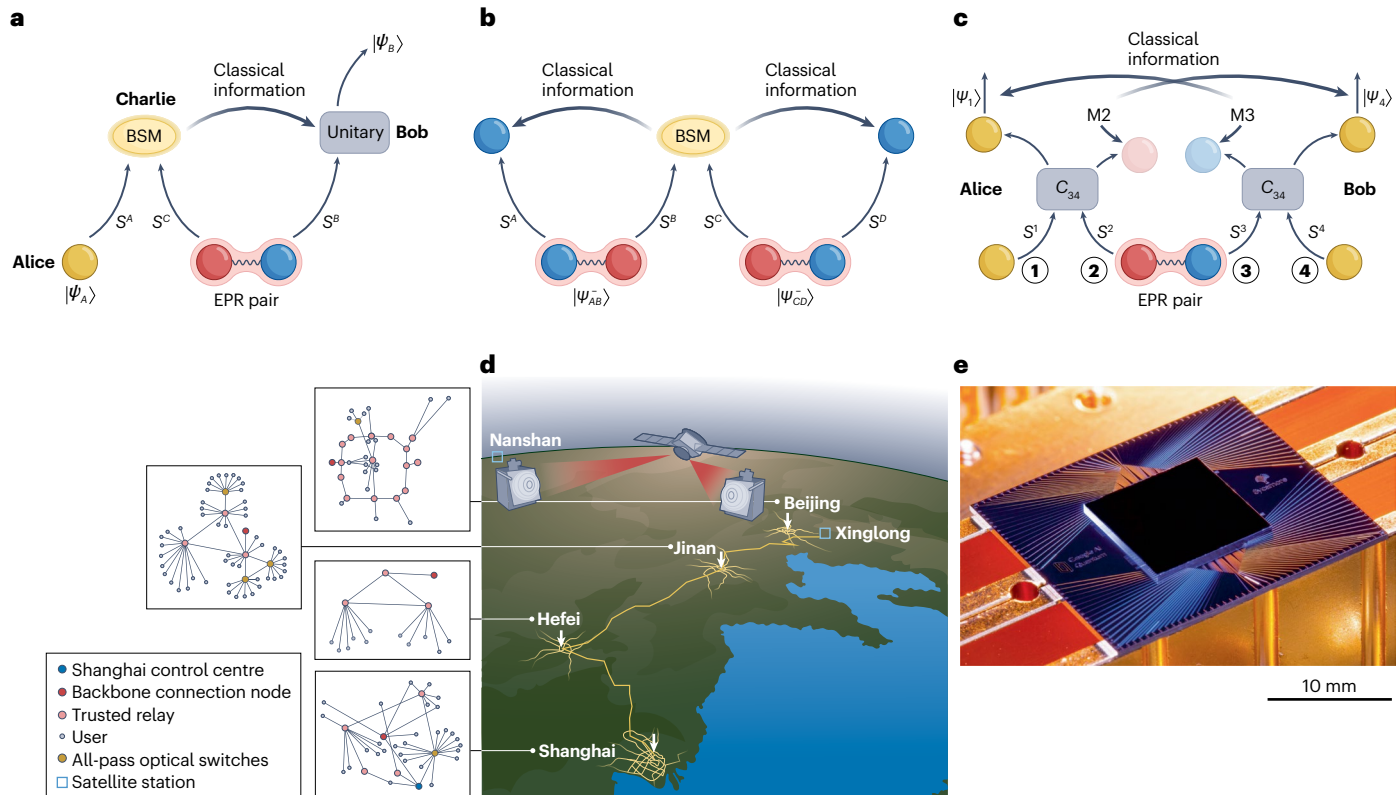

Fig. 1 | Different types of quantum teleportation and examples of applications. **a**, Quantum-state teleportation²: previous shared entanglement, Bell-state measurement (BSM), classical communication and unitary operations are used to transmit unknown quantum states without transmitting the particles themselves. The red, yellow and blue circles represent particles in the quantum teleportation protocol. S^A , S^B , S^C represent the quantum channels for transmitting particles A , B and C . $|\psi_A\rangle$ is the input quantum state. $|\psi_B\rangle$ is the output quantum state. An Einstein–Podolsky–Rosen (EPR) pair is a maximally entangled quantum state. **b**, Quantum entanglement swapping²: individuals in two pairs of independently entangled particles become entangled with two non-neighbouring particles through intermediate BSM. $|\psi_{AB}^-\rangle$ and $|\psi_{CD}^-\rangle$ are maximum entangled states. **c**, Quantum gate teleportation³²: through

entanglement and classical channels, quantum-controlled operations between particles 1 and 2 ($C_{1,2}$) and particles 3 and 4 ($C_{3,4}$) are transferred to controlled operations between non-neighbouring particles 1 and 4. M2 and M3 represent projection measurements of 2 and 3 particles, respectively. **d**, Applications of quantum teleportation in quantum communication: ultra-long-distance quantum-state distribution can be realized through continuous quantum entanglement-swapping operations. **e**, Applications of quantum gate teleportation in quantum computing: quantum gate teleportation is important for distributed quantum computing to establish a connection between quantum computing nodes. Panel **d** is reproduced with permission from ref. 194, Springer Nature Ltd. Panel **e** is reproduced with permission from ref. 9, Springer Nature Ltd.

is $F_{\text{tel}} = 1$, but in real experiments one always obtains a smaller value. It is possible to simulate quantum teleportation using only classical correlations or classical measure–prepare strategies³⁶. This method, called classical teleportation, does not require the distribution of entangled states in advance, but it cannot achieve quantum teleportation with a theoretical fidelity of 1. The most commonly used method to verify nonclassical quantum teleportation is to construct fidelity-based quantum witness. If the fidelity of the transmitted quantum states can exceed the maximum fidelity that can be achieved by classical teleportation (F_{cl}), then the process is called nonclassical teleportation.

For the single-qubit case, the fidelity bound of classical teleportation²⁵ is $F_{\text{cl}} = 2/3$. This fidelity bound was later extended to an unknown state in a d -dimensional single-qudit case^{37,38}:

$$F_{\text{cl}}(d) = \frac{2}{d+1}. \quad (3)$$

According to the fidelity criterion, not all entangled states can be used for nonclassical teleportation. However, a new benchmark has been proposed in recent years, which uses all the information available in the teleportation experiment and proves that all entangled states can achieve nonclassical quantum teleportation^{26,39–41}. The underlying idea of this approach is to carefully consider all the information in quantum teleportation, such as the density matrix of the input and output states, to show more nonclassical properties of quantum teleportation⁴².

Port-based teleportation is an important variant of quantum teleportation^{3,33}, which does not require any corrections on the side of the receiver (Bob). However, the disadvantage of this scheme is that the fidelity of teleportation converges to unity only when an infinite number of Bell pairs are shared. In the qubit case, in fact, it has been demonstrated that it is impossible to realize nonclassical quantum teleportation when sharing one or two Bell pairs. Only when more than three Bell pairs are used, this scheme can achieve an average fidelity higher than two-thirds (reviewed elsewhere³³). In recent years, port-based teleportation has

been widely expanded, for example, to improve its efficiency^{43–45} and to propose high-dimensional⁴⁶ and continuous variable (CV) port-based teleportation⁴⁷. With the development of multicopy entanglement technology^{48,49} and joint measurements^{50,51}, the first experimental demonstration of port-based teleportation can be realized.

Quantum teleportation-based theoretical applications

Quantum teleportation can not only be applied to practical tasks such as quantum communication or quantum computing but also can be used as an important theoretical tool in the theory of quantum information.

Quantum channel simulation⁵² has been used to design a general and dimension-independent technique that reduces adaptive protocols into a block form⁵³. It simplifies the mathematical expression of complex adaptive protocols (for example, local operations and classical communication). This technique is called ‘teleportation stretching’ and is especially powerful when certain protocols are implemented over teleportation-covariant channels⁵³ (such as Pauli, erasure⁵⁴ or Gaussian channels⁵⁵). With this new tool, scientists established the ultimate capacity limits of CV and discrete-variable (DV) quantum key distribution in point-to-point lossy^{53,56}, multipoint⁵⁷, repeater-assisted^{58,59} and network⁶⁰ quantum communications. Owing to its capability to simplify adaptivity, teleportation stretching is used to achieve the ultimate precision of adaptive noise estimation for any teleportation-covariant channel, thus extending the teleportation channel simulation technique to quantum metrology^{61–63} and quantum channel discrimination^{64,65}. Note that port-based teleportation is also an important tool in the theory of quantum information, for example, in the optimization^{66,67} and resource quantification^{68,69} of programmable quantum processors, and for the exploration of the fundamental limits of quantum channel discrimination^{64,65}.

Quantum teleportation also has a role in understanding many physical phenomena such as quantum catalysis⁷⁰, quantum decoherence^{71,72}, directly measuring quantum wave function⁷³, macroscopic quantum⁷⁴, the indistinguishability of photons^{75,76} and so on.

Quantum teleportation of complex quantum states

Photonic systems have various DoFs such as polarization⁷⁷, orbital angular momentum (OAM)⁷⁸, time bins⁷⁹, path⁸⁰ and frequency⁸¹, most of which can encode in high dimensions. In the real world, a single particle often contains many DoFs, forming a complex quantum state. BSM is the key technology of qubit and complex quantum-states teleportation. In the qubit case, owing to the limit of linear optics, the BSM success probability is at most 50%^{82,83}. This limitation can be overcome by using the entanglement in multiple DoFs (hyper-entanglement)^{84–86} or nonlinear processes⁸⁷. Theoretical studies prove that this can also be achieved by adding auxiliary photon pairs^{88,89} or error correction codes^{90,91}. With the help of auxiliary photons, BSM with a success probability of 57.9% was reported in an experiment⁹². In the case of complex quantum states, the implementation of BSM is more difficult. In this section, we discuss quantum teleportation of photonic complex quantum states, including multiple DoFs quantum states, high-dimensional quantum-states and hybrid systems, the ultimate goal being to teleport all the information of a quantum system.

Quantum states in multiple degrees of freedom

A single quantum particle can naturally have different internal and external DoFs with coherent coupling between them. Multiple DoFs represent more operational possibilities and can be used to implement

more transmission protocols such as superdense quantum teleportation^{93,94} and quantum teleportation from polarization to OAM DoFs⁹⁵. A basic challenge is to teleport multiple DoFs at the same time, which is necessary for a complete description of quantum particles.

Achieving multi-DoF quantum teleportation requires sharing hyper-entanglement in advance and implementing BSM on multiple DoFs. In photonic systems, the most difficult task is to implement hyper-BSM because it requires coherent controlled gates between independent qubits of different DoFs and measuring one of the DoFs without interfering with others⁹⁶. In 2007, it was theoretically proved that it is impossible to distinguish hyper-entangled Bell states deterministically using only linear optics without auxiliary particles⁹⁷ because BSMs with different DoFs will interfere with each other, leading to failure of simultaneous recognition of all hyper-entangled Bell states. However, some protocols have been proposed for quantum teleportation with multiple DoFs^{98,99} and in 2015, scientists successfully overcame this challenge and simultaneously teleported photonic polarization and OAM DoFs for the first time¹⁵ (Fig. 2a). This was possible owing to the creative use of quantum non-demolition measurement (QND), which refers to the observation of a single photon without destroying it and preserving its quantum information intact. Interestingly, quantum teleportation assisted by entanglement can achieve probabilistic QND detection. The protocol in ref. 15 can also be extended to the quantum teleportation of more DoFs at the same time.

Researchers have teleported five hyper-quantum states with a fidelity greater than the classical upper bound of 0.4 for simultaneous quantum teleportation of two DoFs state in one photon^{37,38}. The last teleported quantum state was a hyper-entangled state, which is an entangled state formed by polarization and OAM DoF on the same photon and its fidelity exceeded the bound of the entangled state (0.5)¹⁰⁰. Because of the existence of auxiliary particles, the whole quantum teleportation was a six-photon experiment, and the photon counting rate was approximately 15 clicks per hour.

Photon hyper-entanglement has been realized with two or more DoFs^{101–104} and can be distributed over an 11-km fibre channel¹⁰⁵ and a 1.2-km free-space channel¹⁰⁶. When this is combined with QND measurement, one can expect that long-distance quantum teleportation of more DoFs will be achieved in the future.

Quantum states in high dimensions

Compared with two-level systems (qubits), high-dimensional systems (multilevel systems encoding qudits) are more prevalent in nature. The ability to coherently control high-dimensional quantum states is important for developing advanced quantum technologies^{80,81,107–109}. Compared with conventional qubit systems, qudit systems can offer extended possibilities such as both higher capacity^{110–112} and more noise resilience in quantum communications^{113–115}, more efficient quantum simulation¹¹⁶ and computation¹¹⁷ and greater violation of Bell inequalities¹¹⁸.

The challenges in high-dimensional quantum teleportation are: preparing high-quality high-dimensional entanglement sources and implementing high-dimensional BSMs¹². Progress has been made in developing high-dimensional entanglement preparation technologies that use OAM⁷⁸, time bins⁷⁹, paths^{80,119} and frequency⁸¹. Achieving high-dimensional BSM has become urgent for realizing high-dimensional quantum teleportation.

In 2002, it was pointed out that partial high-dimensional BSM requires additional auxiliary particles¹²⁰. The key insight is that it is impossible to clearly distinguish a single Bell state from other $d^2 - 1$

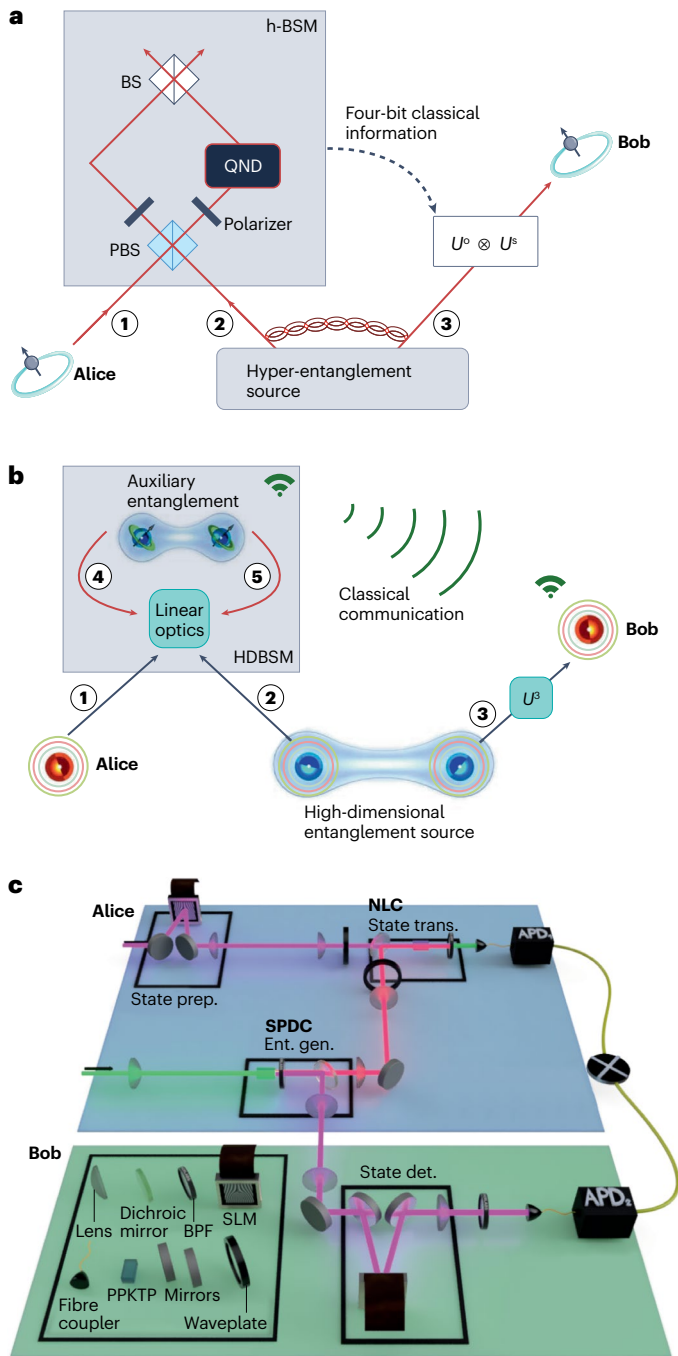

Fig. 2 | Teleportation of photonic complex quantum states. **a**, Concept for quantum teleportation with multiple degrees of freedom (DoFs)¹⁵. The polarization and orbital angular momentum (OAM) DoFs of a photon are teleported simultaneously. To avoid the influence of the Bell-state measurement (BSM) of the polarization DoF (in PBS) on the OAM DoF (in BS), the experimenter used a quantum non-demolition measurement (QND), which is based on assisted entanglement quantum teleportation. The success probability of the final multiple-DoF BSM is 1/32. U^o and U^s represent the unitary operations on OAM and spin DoFs, respectively. **b**, Concept for quantum teleportation of a 3D path state. To realize the path DoF of the 3D BSM, a pair of entangled photons is used to assist in ref. 13 (as illustrated here), and a single-photon-assisted Fourier transform with three inputs and three outputs is used in ref. 14. In these two experiments, the success probabilities of the 3D BSM are 1/162 and 1/81, respectively. **c**, Concept for high-dimensional OAM^{124,125} and Hermite-Gaussian-mode¹²⁵ quantum teleportation. The experimenter prepared the spatial-mode entangled state through SPDC. HDBSM can be achieved using mode conservation in the up-conversion of a nonlinear crystal (NLC). APD, avalanche photodiode detector; BS, beam splitter; h-BSM, hybrid Bell-state measurement; HDBSM, high-dimensional Bell-state measurement; PBS, polarization beam splitter; SLM, spatial light modulator; SPDC, spontaneous parametric down-conversion; U^{β} , 3D unitary operation. Panel **a** is reproduced with permission from ref. 15, Springer Nature Ltd; panel **b** is reproduced with permission from ref. 13, APS; panel **c**, image courtesy of Berenice Sephton.

between these two experiments is that the two research groups used different high-dimensional BSM schemes. In one experiment, a Fourier transformation with three inputs and three outputs was used, which requires an auxiliary particle¹⁴. This method can be extended to any number of dimensions, requiring $(d - 2)$ auxiliary photons. This experiment requires a pair of 3D entangled photons, a transmitted photon and an auxiliary photon, finally resulting in a four-photon experiment. Twelve states from four mutually unbiased bases were transmitted¹²² with an average fidelity of $75 \pm 1\%$, which exceeds the classical limit ($1/2$) and the genuine 3D limit ($2/3$). The count rate of this experiment was 400 counts per hour.

In the other experiment, a pair of polarization-entangled states was used as an auxiliary in the 3D BSM¹³ (Fig. 2b). This method can also be extended to any number of dimensions, requiring $\log_2(d - 1)$ entangled pairs. Nine information-complete states were teleported, and the process matrix of quantum teleportation was reconstructed with a fidelity of $F = 59.6 \pm 3.7\%$. Genuine high-dimensional quantum teleportation was verified to have been achieved by calculating the non-simulability of the process matrix from 2D quantum teleportation²⁶. Because entangled-photon pairs were used as auxiliary particles, the final experiment was a six-photon experiment with a count rate of 10 counts per hour.

The limitation of linear optics in BSM is mainly due to the fact that photons do not interact with each other, but this can be overcome by using a nonlinear photon process. In 2000, nonlinear processes were successfully used for simultaneous deterministic measurement of four polarized Bell states⁸⁷. In 2022, two experiments used a nonlinear process to teleport a high-dimensional photonic quantum state, with one experiment encoding the state in OAM and the other encoding it in Hermite-Gaussian (HG) modes. The core principle of using nonlinearity for high-dimensional BSM is that two photons in different high-dimensional Bell states acquire distinguishable single-photon states in the up-conversion process¹²³ (Fig. 2c).

In an experiment¹²⁴ using 3D OAM BSM, the average quantum teleportation fidelity of 12 mutually unbiased base quantum states

states using only linear optics, and all Bell states can only be divided into several categories^{97,111}. Similar to the concept of genuine multipartite entanglement, genuine high-dimensional teleportation cannot be simulated by low-dimensional quantum teleportation with a fidelity exceeding $(d - 1)/d$. In 2017, experimenters successfully demonstrated the teleportation of multiple OAM states¹²¹, which makes the simultaneous transmission of 2D subspaces possible with high-dimensional quantum states.

In 2019, genuine 3D quantum teleportation was realized in two experiments^{13,14} using the path DoF of photons (Fig. 2b). The difference

was $F = 0.879$, which proves that it was nonclassical and a genuine high-dimensional process. Another experiment¹²⁵ (Fig. 2c) achieved high-dimensional quantum teleportation with 9D HG modes in addition to OAM. The fidelity was $99 \pm 3\%$ for 4D OAM states and $81 \pm 2\%$ for 9D HG mode states. Although these two experiments used a coherent source, with future advances in nonlinear optics they could also be performed at single-photon level without changing the single-entangled-pair configuration.

Note that an optical image has been successfully teleported by exploring the full transverse spatial entanglement¹²⁶. Combined with phase information, this technology is expected to realize quantum teleportation of spatial mode wave functions in the future¹²⁷.

The concepts and techniques of the experiments discussed in this section can be transferred to other high-dimensional DoFs. Combining them with high-dimensional entanglement distribution technology^{81,106,119,128,129} can achieve high-dimensional quantum teleportation over a long distance. With the development of high-dimensional quantum memory technologies^{130–135}, high-dimensional quantum teleportation will hopefully be used in high-dimensional quantum networks¹³⁶ to improve performances.

Quantum states in continuous variables and hybrid approaches

Infinite-dimensional Hilbert spaces, which are CV systems^{55,137}, are important to optical quantum teleportation³. In the early years, CV quantum teleportation was demonstrated in optical modes¹³⁸ and collective spins of atomic ensembles^{139,140}.

CV quantum teleportation is not only an important tool for Gaussian channel simulation⁵² but also to other theoretical studies. For example, a resource theory framework has been constructed to calculate the minimum entanglement consumption required for CV quantum teleportation^{56,141–144}. Furthermore, a concatenated error-correction method based on CV quantum teleportation has been used to build a loss-tolerant quantum repeater architecture¹⁴⁵. A sequential phase estimation protocol enabled by repeated CV teleportation has shown both super resolution and super sensitivity¹⁴⁶.

From the experimental point of view, efforts have been dedicated to increasing the capacity of quantum teleportation channels in CV systems. One group innovatively used a high-gain parametric amplifier based on four-wave mixing in an ⁸⁵Rb vapour cell to realize BSM without detection, which avoided the optic-electro and electro-optic conversion required by traditional BSM in a CV system⁵⁵. Using such all-optical feedforward technology, measurement-free all-optical quantum teleportation¹⁴⁷ and quantum entanglement swapping¹⁴⁸ protocols were experimentally realized, which are expected to release the bandwidth limitation of CV quantum information protocols in building broadband quantum networks. Multiplexing optical modes can effectively increase the transmission capacity of quantum teleportation. A CV system was successfully teleported using nine OAM¹⁴⁷ and five optical frequency comb¹⁴⁹ multiplexed channels.

CV quantum information processing benefits from complete BSM, high detection efficiency and unambiguous state discrimination. However, its sensitivity to loss limits its fidelity. DV systems can effectively resist losses, but they are limited by probabilistic operations and BSM. Combining the two in a hybrid architecture could have significant advantages^{150,151}.

Many attempts have been made to teleport hybrid quantum systems but the biggest challenge is preparing hybrid entanglement and special BSM. Hybrid entanglement of Fock-squeezed states¹⁵², cat-Fock

states^{153,154} and polarization-cat states¹⁵⁵ can be used to build hybrid quantum networks. When combined with other DV quantum states or entanglement types such as polarization entanglement and Fock-state entanglement, this can achieve teleportation of hybrid quantum states or hybrid quantum entanglement swapping.

BSM is also a key factor in such experiments. For instance, using a cat-state BSM, the experimenter can teleport a CV cat qubit to a DV Fock qubit state¹⁵³. Although only one Bell state has been recognized in this experiment¹⁵³, in principle, four Bell states can be identified deterministically at the same time by including a detector that can distinguish the number of photons. Entanglement between a DV polarization qubit and CV opposite-amplitude coherent state has been realized through quantum entanglement swapping using a BSM of a polarization DoF¹⁵⁵. Heralded creation of a hybrid entrance has been realized at a 47-ns delay distance using a Fock-state BSM with a single-shot counter and a homodyne detector for hybrid entanglement swapping¹⁵⁴. These experiments open the prospect of connecting heterogeneous nodes in a network with increased integration and new functions.

Quantum teleportation for quantum communication

Quantum teleportation can be used to transmit an unknown quantum state without it actually travelling along the way, which is important in quantum communication⁴. The quantum non-cloning principle³⁶ that an unknown quantum state cannot be copied limits the transmission distance of quantum communication. For a direct fibre-based link from the transmitter to the receiver, the key rate decreases exponentially with the transmission distance and cannot surpass the Pirandola-Laurenza-Ottaviani-Banchi bound $-\log_2(1 - \eta)$ ⁵³, where η denotes the transmittance of the link. As a variant of quantum teleportation, quantum entanglement swapping (Fig. 1b) can be used to overcome this limit. The basic principle of quantum entanglement swapping is that the key rate attenuation can be reduced from exponential to polynomial through segmented communication. Quantum memories¹⁵⁶ can effectively improve the efficiency of quantum entanglement swapping among multiple nodes. Memory-based quantum entanglement swapping can be used in a quantum repeater⁵ and has been demonstrated in an atomic ensemble¹⁵⁷, a single atom^{6,158}, an ion trap¹⁵⁹, rare-earth solid state memory^{160,161} and a nitrogen-vacancy (NV) centre¹⁶². However, these experiments have mainly focused on the platforms or on short distances. The progress in quantum repeaters has been discussed in other reviews^{163–166}. In recent years, interesting variations of teleportation have also emerged in quantum communication, such as controlled quantum teleportation^{112,167} and teleportation of a shared quantum secret¹⁶⁸.

We subsequently overview recent developments of long-distance quantum teleportation, including photonic quantum teleportation based on optical fibre networks, free-space satellites and integrated systems that are expected to be implemented on a large scale.

Optical fibre network

In a future quantum network^{19,169}, multiple nodes will share entanglement through quantum repeaters to form a quantum entanglement connection. Quantum networks with remote nodes require each node to have an independent quantum entanglement source, and photons from different sources are indistinguishable when quantum interference occurs after long-distance distribution¹⁷⁰.

Achieving high-visibility and highly stable interference between photons in a long-distance optical fibre network requires

a high-precision synchronization system and a quantum channel stabilization system. However, in the real world, the effective length and polarization of the quantum channel will fluctuate, making the two photons distinguishable and reducing the interference visibility. This situation did not exist in the previous proof-of-concept local experiments in stable laboratory environments^{171,172}.

In 2016, two groups independently realized long-distance quantum teleportation in metropolitan optical networks in the cities of Hefei and Calgary (Fig. 3a).

In the Hefei experiment¹⁷, the transmitted state was encoded with true single photons⁷⁷ at the telecom wavelength, and an active feed-forward scheme was used to increase the BSM success probability to 50%. This was the first time quantum teleportation was achieved with independent quantum sources, previous entanglement distribution and active feed-forward operations simultaneously in a long-distance optical fibre network. In this experiment, the error signal derived from the photon arrival time in the feedback loop was used to reduce the total arrival time jitter of photons from the remote nodes to 6 ps, which is negligible compared with the photon coherence time of 110 ps.

In the Calgary experiment¹⁸ (Fig. 3a), the transmitted state was not encoded with single photons, but with an attenuated laser beam, a method that can be applied to a decoy state protocol developed through quantum cryptography¹⁷³. This was different from the Hefei experiment in that it used nondegenerate entangled photon sources with wavelengths of 1550 nm and 795 nm. The state was teleported from 1550-nm photons to 795-nm photons, which permits more efficient and robust photon detectors to be used around Bob. These different settings made this experiment achieve a higher transmission rate of 12 clicks per minute.

The aforementioned two experiments show that a quantum network spanning cities is realistic. The entangled photon sources in these experiments were generated through spontaneous parametric down-conversion (SPDC)⁷⁷. The random nature of this process limits the generation rate for multiphoton states, but more recently, great progress has been made in developing on-demand solid-state quantum emitters. Quantum teleportation using solid-state emitters has been demonstrated successfully^{174–177}, providing an alternative high-speed solution to SPDC. The development of superconducting detectors has significantly improved photon detection efficiency in the communication band, thus increasing the teleportation distance to over 100 km^{178–180}. One experiment¹⁸¹ used a high-performance time bin entangled quantum light source with a single-fibre-pigtailed periodically poled lithium niobate (PPLN) waveguide to achieve high-speed quantum teleportation along a 64-km-long fibre channel at a rate of 7.1 Hz. CV quantum teleportation through a 6-km optical fibre has been also realized in the laboratory¹⁸². Some experiments have also verified that decoherence in quantum teleportation can be effectively reduced by regulating the channel noise^{183,184}.

Free space

Owing to the unavoidable photon loss of the distribution channel, the transmission distance of quantum teleportation using optical fibres^{178,179} and ground-free space^{185,186} channels was limited to about 100 km in previous studies. Realizing a 'quantum internet'¹⁸⁷ on a global scale requires greatly expanding the scope of quantum teleportation.

One method is to use quantum repeaters^{164–166} to continuously complete quantum entanglement swapping to extend the distance of photon entanglement over a long distance. However, quantum repeaters need quantum memory¹⁵⁶ and quantum interface¹⁸⁸ technologies

with excellent performance, and these are still in the laboratory verification stage.

Another promising way is to use satellite platforms and space-based links to connect remote modes on Earth. In this case, most of the photon propagation paths are in empty space, which greatly reduces channel loss and decoherence. Many satellite projects have been proposed for quantum communications, such as the Micius satellite¹⁸⁹, the Quantum Encryption and Science Satellite (QEYSSat) project in Canada¹⁹⁰ and the CubeSat Quantum Communications Mission (CQuCoM), undertaken by a joint research team¹⁹¹.

In 2017, quantum teleportation was achieved from a ground observatory station in Ngari to the Micius satellite¹⁶ (Fig. 3b). The ultra-bright four-photon sources had a wavelength of 780 nm¹⁹², the counting rates were $5.7 \times 10^5 \text{ s}^{-1}$ for the teleported photons and $1 \times 10^6 \text{ s}^{-1}$ for the frequency-uncorrelated entangled photon pairs and the fidelity was 0.933. The experiment optimized the efficiency of entanglement distribution and overcame atmospheric turbulence in the uplink by using narrow beam divergence, high bandwidth, high-precision acquisition, pointing and tracking techniques (Fig. 3b). The average teleportation fidelity for the six input states was $F = 80 \pm 1\% > 2/3$. As for CV systems, this scheme can also perform remote quantum teleportation via satellite connection¹⁹³. More complex space-to-ground quantum teleportation is expected to be realized soon and to have a key role in the future space-ground quantum internet¹⁹⁴.

Integrated chips

Integrated quantum information processors provide an excellent opportunity for developing quantum communication with superior performance because of their high stability and scalability. Integrated quantum photonics^{195–197} has made rapid progress in recent years, which has enabled high-quality generation, processing and detection of multiphoton states^{198,199}.

In 2014, quantum teleportation was demonstrated in an ultraviolet-written silicon photonic chip²⁰⁰. However, a major challenge facing this setup is implementing sufficiently high-quality multiphoton sources and multiqubit operators in a single integrated system.

In 2020, another group realized fully integrated interchip quantum teleportation²⁷. The design of on-chip microring resonators (Fig. 3c) achieved a spectral purity of 92% and a two-photon interference of $90.99 \pm 3.91\%$. The heralding efficiency after the resonators was measured to be 50%, which means that the signal photon of a photon pair can escape the resonator with a probability of 50%. The transmitter and receiver were coherently linked by a 10-m single-mode fibre, enabling quantum teleportation between chips. The teleported states were recovered on the receiver chip with an average fidelity of $F = 88.5 \pm 3.7\%$. This chip was also used to prepare three-photon and four-photon Greenberger–Horne–Zeilinger states with fidelities of $F_3 = 73.5 \pm 1.7\%$ and $F_4 = 68.3 \pm 1.4\%$.

Scalable integrated optical quantum chips permit to implement high-dimensional quantum information processing tasks^{80,201}. In 2022, experimenters applied unsupervised machine learning to train an on-chip autoencoder to encode 3D quantum states onto 2D quantum teleportation, observing 3D teleportation with a fidelity of 0.894 (ref. 202). With the development of integrated quantum chips, an on-chip high-dimensional quantum teleportation is expected to be realized, which contains high-dimensional quantum-state transmission and high-dimensional BSM.

Quantum teleportation with an integrated quantum memory has also been investigated. For example, high-frequency nano-optical

a Metropolitan optical networks

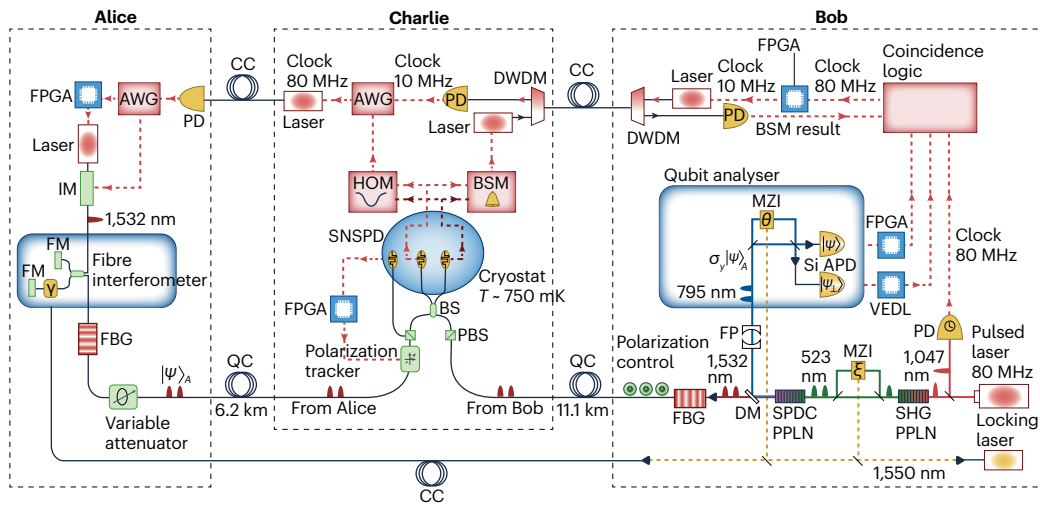

b Free-space satellite

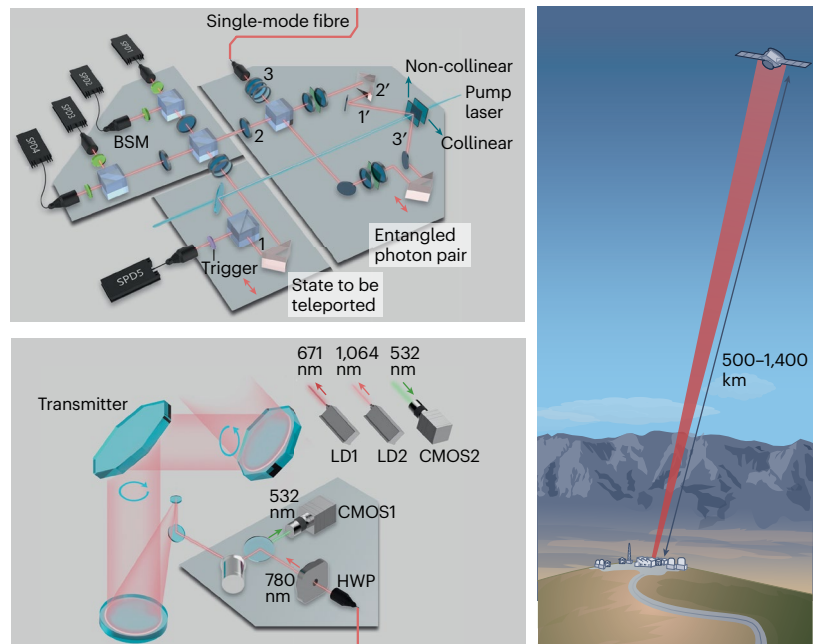

c Integrated optics

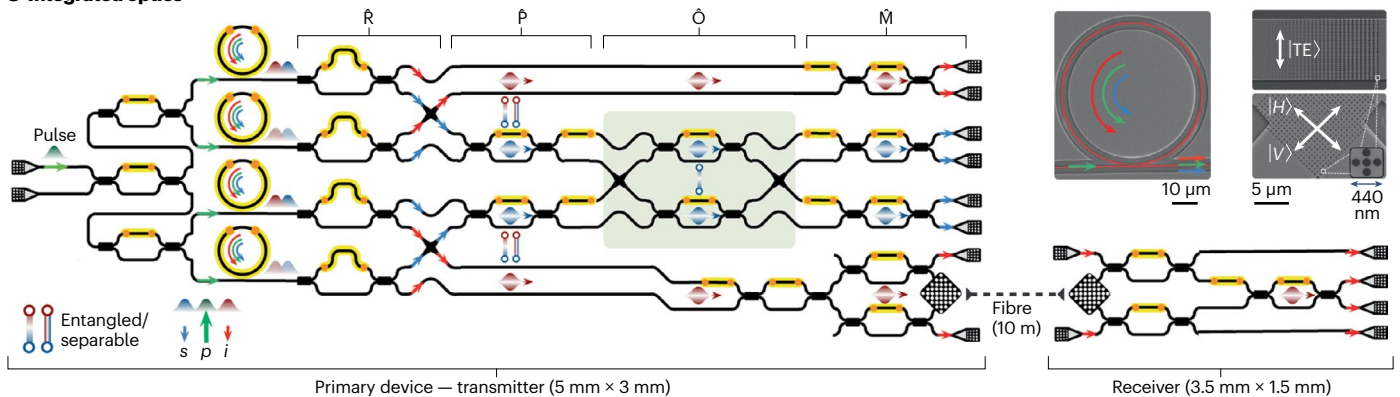

Fig. 3 | Quantum teleportation for quantum communication. **a**, Quantum teleportation was achieved in metropolitan optical networks in the cities of Calgary¹⁸ and Hefei¹⁷. The map shows the experiment in Calgary. The experimenters successfully synchronized two independent photon sources (in nodes A and C) with an interval of 8.2 km. Quantum teleportation was demonstrated in a three-node fibre-optic network with lengths of 6.2 km and 11.1 km. A, B and C represent the nodes of Alice, Bob and Charlie. **b**, Quantum teleportation was realized in free space from an observatory ground station in Ngari to the Micius satellite over a distance of 1,400 km. In the experiment¹⁶, 780-nm photons were used as the quantum communication carriers. In the right figure, the Ngari observation station is on the ground, and the Micius satellite is in the air, and the physical distance between the ground station and the satellite varied from a maximum of 1,400 km to a minimum of 500 km. As a result, the channel loss of the uplink varied from 52 dB to 41 dB. The four-photon source preparation and Bell measurement were completed at the Ngari observatory station. One photon of the entangled photon source was sent to the Micius satellite to establish a ground-to-satellite entanglement distribution. **c**, Quantum teleportation in an integrated chip²⁷. Four microring resonators were prepared

on silicon to generate single photons with high spectral purity and high heralding efficiency by eliminating the requirement of spectral filtering. A connection was established using a 10-m single-mode fibre, enabling quantum teleportation from one chip to another. Subpanels on the right are microring resonator structures and teleportation receiver. HOM, Hong–Ou–Mandel effect; BSM, Bell-state measurement; CC, classical channels; QC, quantum channel; FBG, fibre Bragg grating; IM, intensity modulator; FM, Faraday mirror; MZI, Mach–Zehnder interferometer; BS, beam splitter; PBS, polarization beam splitter; HWP, half wave plate; LD, laser diode; PDs, photodiodes; PPLN, periodically poled lithium niobate; DM, dichroic mirror; FP, Fabry–Perot cavity; FPGA, field-programmable gate array; VEDL, variable electronic delay line; DWDM, dense-wavelength division multiplexers; AWG, arbitrary waveform generators; Si-APD, silicon avalanche photodiodes; SPD, single-photon detector; SNSPD, superconducting nanowire single-photon detectors; CMOS, camera; SHG, second harmonic generation; SPDC, spontaneous parametric down-conversion. Panel **a** is reproduced from ref. 18, Springer Nature Ltd; panel **b** is reproduced from ref. 16, Springer Nature Ltd; panel **c** is reproduced from ref. 27, Springer Nature Ltd.

systems²⁰³ can be used for quantum memory in optical communication and are therefore promising as nodes in a future quantum network. In 2021, a polarization-encoded optical input state was teleported into the joint state of a pair of integrated nanomechanical resonators²⁰⁴. The mechanical coherence lifetimes of the two integrated nanomechanical resonators were $T_1^{(A)} = 1.3 \mu\text{s}$ and $T_1^{(B)} = 1.9 \mu\text{s}$, which should be long enough to store the teleported state until it is read. In 2022, an experiment demonstrated long-distance quantum teleportation from a photonic qubit to a 17.5 μs rare-earth crystal quantum memory through a 1-km fibre channel²⁰⁵. Integrated quantum teleportation will be realized in the future by combining integrated solid-state quantum memory^{206–208} with simultaneously integrated entangled photon sources and interfaces.

Quantum teleportation for quantum computing

Gate quantum teleportation (Fig. 1c) is an important variant of quantum teleportation that distributes local gate operations between spatially separated particles (Fig. 4a).

In 1999, a theoretical proposal suggested that a universal quantum computer could be built using only quantum teleportation, local operations and classical communication³². More importantly, teleportation-based quantum computing can effectively block propagating errors so that fault-tolerant quantum computing can be expanded on a large scale.

Gate teleportation is also the core of quantum computing based on cluster states^{49,209} and other kinds of measurement-based quantum computing²¹⁰. In this model, gate operations can be distributed through quantum gate teleportation among different particles that come from multipartite entangled states.

Both entanglement distribution and state transfer via teleportation are necessary in quantum networks⁶⁰. In a quantum network^{19,187}, quantum teleportation is the core technology for remote connection of quantum computers, to achieve synchronous distributed computing of different nodes^{20,21,211}.

Quantum gates

Quantum gate teleportation was first demonstrated in a photonic system^{212,213} and could be applied in linear optical quantum computing theory²¹⁴. Quantum gate teleportation has also been implemented with superconducting qubits²², trapped ions²³, QED cavities²⁴ and

quantum dot spin qubits^{215,216}. These systems have excellent scalability and are candidates for future large-scale fault-tolerant quantum computers^{217,218}.

In 2018, gate teleportation was demonstrated using a superconducting cavity²¹⁹ coupled to a superconducting circuit qubit²². This setup had a record quantum lifetime (approximately 1 ms) and sub-microsecond feed-forward controls (Fig. 4a). In addition, the experiment used an error-correcting code that uses the bosonic nature of the cavity. This is more robust than standard qubits. With error corrections, the process fidelity of the gate teleportation was increased from $68 \pm 2\%$ to $79 \pm 2\%$. A propagating microwave is an important carrier of the superconducting circuit interface. In another experiment, a propagating coherent microwave state was teleported over a distance of $d = 0.42 \text{ m}$ in the laboratory²²⁰. Superconducting qubit entanglement has achieved a 10-m distribution^{221–224}. These advances lay the foundation for quantum gate teleportation of remotely separated superconducting qubits.

In 2019, an entangled pair of $^{25}\text{Mg}^+$ ions was used to verify deterministic gate teleportation between two $^9\text{Be}^+$ ions²³ (Fig. 4b). From the measurement outcomes, the experimenters determined the quantum process by maximum likelihood estimation and inferred a 95% confidence interval of (0.845, 0.872) for the entanglement fidelity with respect to an ideal C-NOT gate. The interface between a photon and trapped ion has been used to entangle two ion traps 230 m apart²²⁵. In the future, similar technologies can be used to achieve ion-based remotely distributed quantum computing in quantum networks.

In 2021, quantum teleportation was achieved between two QED cavities²²⁶ connected through a 60-m optical fibre²²⁷ (Fig. 4c). This approach demonstrates a new teleportation protocol that, in principle, allows for unconditional teleportation without the need for the commonly used pre-shared entanglement resource. This scheme requires two C-NOT operations between the QED cavity nodes and the auxiliary photon. Using this new quantum teleportation scheme, the experimenters realized a remote C-NOT operation²⁴ between QED cavity nodes with a spacing of 60 m. The experiment achieved an average overlap fidelity of $76.6 \pm 1.0\%$ with ideal Bell states. In this scheme, only one single-photon transmission and measurement is used for teleportation, effectively reducing the consumption of entangled photon pairs, and providing a new solution for large-scale and long-distance quantum networks.

Individual electron spins in semiconductor quantum dots are a candidate platform for quantum computing owing to their long correlation time and scalability²²⁸. Two experiments used quantum dot spin

qubits to realize quantum-state teleportation, entanglement swapping and gate teleportation^{215,216}, which can be used to create and manipulate long-range states and correct errors in quantum dot spin qubits.

a Scheme of distributed quantum computing and superconducting qubit

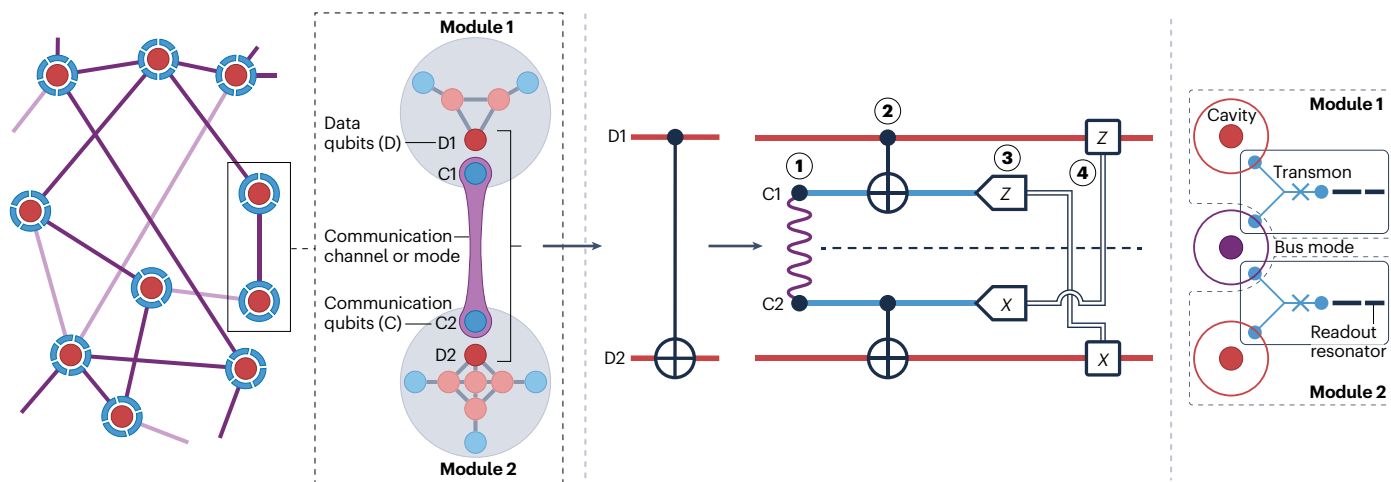

b Ion traps

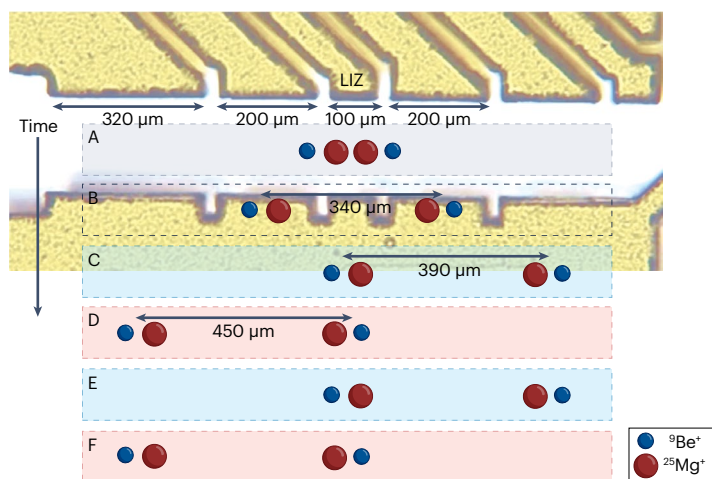
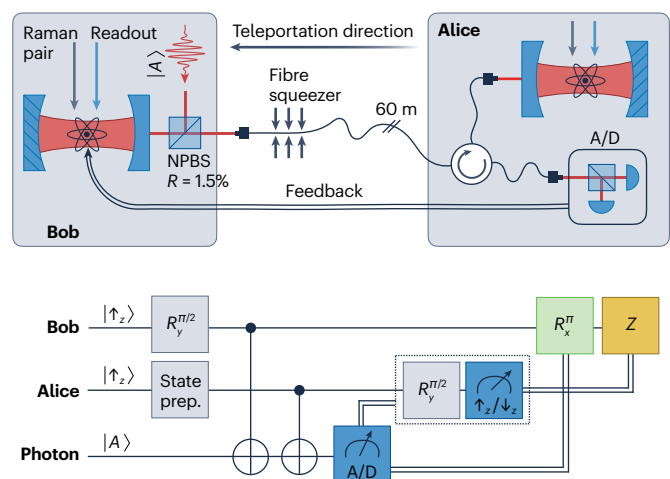

Fig. 4 | Quantum gate teleportation for quantum computing. a, Concept of distributed quantum computing and gate teleportation with superconducting qubits. The left side illustrates distributed quantum computing in a quantum network. Divide the particles in each node of quantum computing into data qubit (qubits) (red) and communication qubit (qubits) (blue). Each node is connected by entanglement (purple), and different nodes perform synchronous quantum computing through quantum gate teleportation. The circuit diagram for gate quantum teleportation is shown in the middle; it consists of four steps: first, entanglement of two communication qubits (blue line); second, controlled gate operation of data qubit (red line) to communication qubit; third, perform X and Z Pauli measurements on two communication qubits separately; fourth, perform X and Z operations on the data qubits on the basis of the measurement results. The right side shows quantum gate teleportation with superconducting qubits²². The gate teleportation consists of a logical qubit defined as a coaxial quarter wavelength ($\lambda/4$) 3D cavity (data qubit (red)) and an entanglement qubit defined as a Y-shaped transmon qubit (communication qubit (blue)). **b**, Setup for quantum gate teleportation with trapped ions²³. The blue dots represent ${}^9\text{Be}^+$, and the red dots represent ${}^{25}\text{Mg}^+$ ions. A–F shows

c Cavity QED



ions trapped in a segmented linear Pauli trap, which can be moved between different regions of the trap. Therefore, the experimenters can simplify the C-NOT gate by using only one laser interaction zone (LIZ) and transporting the separated qubits to this location. The experiment demonstrates a deterministic teleported C-NOT between two ${}^9\text{Be}^+$ ions using a shared engaged pair of ${}^{25}\text{Mg}^+$ ions. **c**, Quantum-state teleportation in cavity quantum electrodynamics (QED)²²⁷. Two cavity QED setups are connected with a 60-m-long optical fibre. This is different from the previous quantum teleportation protocols because a single photon is used as the medium, and the QED cavity on both sides completes the C-NOT gate operation in turn with the single photon and on the QED cavity of Alice, and the measurement results are reported to Bob through the classical channel to complete the quantum teleportation. This protocol can achieve C-NOT gate operation of two remotely located QED cavity nodes with slight changes²⁴. A/D, antidiagonal/diagonal polarization; NPBS, non-polarized beam splitter. Panel **a** reproduced from ref. 22, Springer Nature Ltd; panel **b** reproduced from ref. 23, AAAS; panel **c** reproduced from ref. 227 under a Creative Commons licence CC BY 4.0.

Multiple nodes

In future quantum networks, qubits implemented in atomic²²⁷, trapped-ion²³ and various other systems^{22,229} will form network nodes for quantum computing, quantum sensing and other applications. Through flying qubits, such as microwave photons, quantum teleportation will be used to send quantum information between these quantum nodes. Connecting multiple nodes or non-neighbouring nodes becomes a major challenge as the number of nodes increases. In recent years, entanglement between three cold atomic ensembles²³⁰ or three independent NV centre spins²³¹ has been achieved by optical interference postselection or local spin entanglement. In these studies, the three nodes were neighbours, and the non-neighbouring nodes were connected by quantum teleportation.

In 2022, an experiment showed quantum teleportation between NV qubit nodes without direct connection through quantum channels²⁸. The experimenters used NV qubits as the three nodes to construct a quantum network and used NV electronic spin as the communication qubit and a nearby ¹³C nuclear spin as a memory qubit. First, an entanglement of non-neighbouring nodes was established through quantum entanglement swapping, and then quantum teleportation was conducted between two nodes. The average teleported state fidelity was $70.2 \pm 1.1\%$ at a rate of 0.5 per minute. Compared with previous efforts to entangle three nodes^{230,231}, this experiment clearly demonstrated multinode quantum repeaters^{164–166} which is an important functional tool in quantum networks. The advantage of memory qubits is that they can be used to read out and protect qubit information while generating entanglement and, at the same time, achieve the real-time rejection of false remaining signals. Quantum teleportation between multiple nodes should also be realized in other solid-state^{160,161} or atomic systems^{6,158} in the near future.

Quantum error correction

Quantum error correction is essential for reliable quantum information processing on a large scale^{217,218}. Quantum teleportation is an important means to encode physical qubits into logical qubits²³².

In 2021, two experiments demonstrated the teleportation of physical qubits to fault-tolerant logical qubits. In one experiment²³³, a photonic polarization qubit was teleported to a logical qubit of the nine-qubit Shor code²³⁴, and the nine qubits were encoded in three DoFs (polarization, path and OAM) of three photons. A bit flip of one of the nine physical qubits encoding the logical qubit resulted in a change in the error syndrome measurements and thus could be excluded. After correction, the average fidelity of the three teleported states was $F = 78.6 \pm 1.7\%$, well exceeding the classical bound of two-thirds.

The other experiment²³⁵ simulated the teleportation of a physical superconducting qubit to a logical code qubit (the Majorana zero mode qubit²³⁶). The Majorana code is a quantum error-detecting code for phase-flip errors that is used to improve the average fidelity of teleportation for six states from $70.76 \pm 0.35\%$ to $84.60 \pm 0.11\%$, well beyond the classical bound in either case.

Outlook

Since 2015, developments in quantum teleportation technology have mainly focused on transitioning from simple to complex quantum states and from proof-of-principle demonstrations to practical applications. Table 1 summarizes the performance of various systems in quantum teleportation. Flying photonic qubits are often used in long-distance quantum communication media, and atomic and solid-state systems are often used in quantum computing nodes. The two

Table 1 | Comparison of quantum teleportation advances since 2015

Quantum technology	Bell efficiency	Fidelity	Maximum distance	Quantum memory
Photonic qubit (or qudit)				
Multiple DoF ¹⁵	1/32	0.68	Table-top	NA
Path (entangled photon pair assisted) ³	1/162	0.684	Table-top	NA
Path (single-photon assisted) ¹⁴	1/81	0.75	Table-top	NA
OAM mode ^{124,125}	1/16 (ref. 125)	0.99 (ref. 125)	Table-top	NA
HG mode ¹²⁵	1/81	0.81	Table-top	NA
Time bin (fibre network) ^{738,178–181}	50% ¹⁷	0.85 (ref. 17)	103 km (ref. 178) ^a	NA
On-demand photon ^{174–176}	25%	0.883 (ref. 176)	Table-top	NA
Polarization (free-space satellite) ¹⁶	25%	0.80	1,400 km ^b	NA
Integrated optics ²⁷²⁰²	25%	0.894 (ref. 202)	10 m ^a	NA
Optical modes				
CV ¹⁸²	100%	0.62	6 km ^a	NA
Multiplexing CV ^{147,149}	100%	0.78 (ref. 149)	Table-top	NA
Hybrid ^{152–155}	100% ¹⁵²	0.93 (ref. 155)	47 ns (ref. 154) ^b	NA
Propagating microwaves ²²⁰	100%	0.689	0.53 m ^c	NA
Solid state				
Rare-earth crystal ²⁰⁵	50%	0.86	1 km ^a	17.5 μs
Optomechanical memory ²⁰⁴	25%	0.75	0.2 m ^a	1.9 μs
NV centre ²⁸	100%	0.688	Table-top	^d
Superconducting qubit ²²	100%	0.79 ^e	Chip	1 ms
Quantum dot spin ^{215,216}	25%	0.95 (ref. 216)	Chip	NA
Trapped atoms				
Cavity QED ^{24,227}	100%	0.833 (ref. 227)	60 m ^a	^d
Ion trap ²³	100%	0.845 ^e	Chip	^d

CV, continuous variable; DoF, degree of freedom; HG, Hermite-Gaussian; NA, not applicable; NV, nitrogen vacancy; OAM, orbital angular momentum; QED, quantum electrodynamics.

^aOptical fibre. ^bFree space. ^cFree-space superconducting coaxial cable. ^dThere is a memory, but no specific memory time. ^eQuantum gate teleportation.

can be combined to construct quantum networks using quantum teleportation¹⁹.

Developments in the teleportation of complex quantum states have mainly focused on photonic systems, the challenges being the preparation of entanglement¹² and the BSM in complex quantum states¹²⁰. In photonic systems, BSM with multiple DoFs or high dimensions in linear optics requires auxiliary particles^{13–15,88,89,92,237} or nonlinear processes^{124,238}. The randomness of SPDC^{77,239} and the inefficient nonlinear process²⁴⁰ limit the success probability of quantum teleportation. Quantum teleportation via a deterministic photon source^{49,241,242} and highly efficient on-chip nonlinearity²⁴³ may be the

key to improving this. These new technologies will also greatly increase the transmission rate of quantum teleportation based on urban fibre-optic networks and satellites. High-dimensional entanglement of trapped-ion^{108,244}, NV centres¹⁰⁹ and superconducting qubits^{107,244} have also been reported. Deterministic BSM can be performed in these systems without auxiliary particles^{28,224,245}. These advances suggest that quantum teleportation of complex states will be realized in these systems in the near future.

Quantum teleportation can be used in quantum communication to overcome the distance limit of direct transmission of quantum states. A variation of quantum teleportation is quantum entanglement swapping, which is the core technology in quantum repeaters²⁴⁶. A quantum memory is essential in synchronizing entanglement swapping of all nodes to maximize the quantum information transmission rate^{156,164}. Quantum swapping can be enhanced by developing large-bandwidth, long-life and high-fidelity solid-state memories^{160,161} and atomic memories^{247,248}. The method of increasing the success probability of BSM by adding auxiliary photons^{88,89,92} or using error correction codes^{90,91} is expected to be applied in quantum teleportation in the near future to increase the quantum communication rate of each node. We can also expect quantum repeaters to achieve quantum communication beyond the rate of direct optical fibre communication in the near future.

Developments in the application of quantum teleportation in distributed quantum computing have focused mainly on solid-state systems (superconducting qubits and NV centres) and atomic systems (QED cavities and ion traps). Although a quantum advantage has been demonstrated in quantum computing^{9,249}, many quantum algorithms (including Shor's and Grover's algorithms) require large numbers of qubits and long-range interactions. Quantum teleportation is expected to solve the problem of long-range interactions between different particles^{20,32,250}. Arrays of neutral atom^{251,252}, integrated magneto-optical traps²⁵³ and ion trap chips²⁵⁴ have effective scaling potential, which is the dawn of large-scale distributed quantum computing based on quantum teleportation^{20,21}.

Quantum teleportation will be necessary for quantum networks with photons interfacing with solid-state or atomic systems as the computing nodes¹⁹. Two-node gate teleportation has been achieved over a distance of 60 m, but there are still major challenges before achieving a distance on the scale of kilometres or more. One of these challenges is due to photons emitted or absorbed by atomic or solid-state systems often being incompatible with existing fibre-optic networks. Advances in areas such as on-chip frequency conversion technology²⁴³, non-degenerate entanglement sources²⁵⁵, hybrid quantum teleportation⁷⁴ and hollow-core optical fibres²⁵⁶ should help overcome this issue.

Published online: 24 May 2023

References

- Horodecki, R., Horodecki, P., Horodecki, M. & Horodecki, K. Quantum entanglement. *Rev. Mod. Phys.* **81**, 865 (2009).
- Bennett, C. H. et al. Teleporting an unknown quantum state via dual classical and Einstein-Podolsky-Rosen channels. *Phys. Rev. Lett.* **70**, 1895 (1993).
- Pirandola, S., Eisert, J., Weedbrook, C., Furusawa, A. & Braunstein, S. L. Advances in quantum teleportation. *Nat. Photon.* **9**, 641–652 (2015).
- Gisin, N. & Thew, R. Quantum communication. *Nat. Photon.* **1**, 165–171 (2007).
- Briegleb, H.-J., Dür, W., Cirac, J. I. & Zoller, P. Quantum repeaters: the role of imperfect local operations in quantum communication. *Phys. Rev. Lett.* **81**, 5932 (1998).
- Zhang, W. et al. A device-independent quantum key distribution system for distant users. *Nature* **607**, 687–691 (2022).
- Preskill, J. Quantum computing in the NISQ era and beyond. *Quantum* **2**, 79 (2018).
- Zhong, H.-S. et al. Quantum computational advantage using photons. *Science* **370**, 1460–1463 (2020).

- Arute, F. et al. Quantum supremacy using a programmable superconducting processor. *Nature* **574**, 505–510 (2019).
- Bouwmeester, D. et al. Experimental quantum teleportation. *Nature* **390**, 575–579 (1997).
- Braunstein, S. L. & Kimble, H. J. Teleportation of continuous quantum variables. *Phys. Rev. Lett.* **80**, 869 (1998).
- Erhard, M., Krenn, M. & Zeilinger, A. Advances in high-dimensional quantum entanglement. *Nat. Rev. Phys.* **2**, 365–381 (2020).
- Hu, X.-M. et al. Experimental high-dimensional quantum teleportation. *Phys. Rev. Lett.* **125**, 230501 (2020).
- Luo, Y.-H. et al. Quantum teleportation in high dimensions. *Phys. Rev. Lett.* **123**, 070505 (2019).
- Wang, X.-L. et al. Quantum teleportation of multiple degrees of freedom of a single photon. *Nature* **518**, 516–519 (2015).
- Ren, J.-G. et al. Ground-to-satellite quantum teleportation. *Nature* **549**, 70–73 (2017).
- Sun, Q.-C. et al. Quantum teleportation with independent sources and prior entanglement distribution over a network. *Nat. Photon.* **10**, 671–675 (2016).
- Valivarthi, R. et al. Quantum teleportation across a metropolitan fibre network. *Nat. Photon.* **10**, 676–680 (2016).
- Wehner, S., Elkouss, D. & Hanson, R. Quantum internet: a vision for the road ahead. *Science* **362**, eaam9288 (2018).
- Jiang, L., Taylor, J. M., Sørensen, A. S. & Lukin, M. D. Distributed quantum computation based on small quantum registers. *Phys. Rev. A* **76**, 062323 (2007).
- Monroe, C. et al. Large-scale modular quantum-computer architecture with atomic memory and photonic interconnects. *Phys. Rev. A* **89**, 022317 (2014).
- Chou, K. S. et al. Deterministic teleportation of a quantum gate between two logical qubits. *Nature* **561**, 368–373 (2018).
- Wan, Y. et al. Quantum gate teleportation between separated qubits in a trapped-ion processor. *Science* **364**, 875–878 (2019).
- Daiss, S. et al. A quantum-logic gate between distant quantum-network modules. *Science* **371**, 614–617 (2021).
- Massar, S. & Popescu, S. Optimal extraction of information from finite quantum ensembles. *Phys. Rev. Lett.* **74**, 1259 (1995).
- Cavalcanti, D., Skrzypczyk, P. & Šupić, I. All entangled states can demonstrate nonclassical teleportation. *Phys. Rev. Lett.* **119**, 110501 (2017).
- Llewellyn, D. et al. Chip-to-chip quantum teleportation and multi-photon entanglement in silicon. *Nat. Phys.* **16**, 148–153 (2020).
- Hermans, S. et al. Qubit teleportation between non-neighbouring nodes in a quantum network. *Nature* **605**, 663–668 (2022).
- Calsamiglia, J. & Lütkenhaus, N. Maximum efficiency of a linear-optical Bell-state analyzer. *Appl. Phys. B* **72**, 67–71 (2001).
- Weinfurter, H. Experimental bell-state analysis. *Europhys. Lett.* **25**, 559 (1994).
- Braunstein, S. L. & Mann, A. Measurement of the Bell operator and quantum teleportation. *Phys. Rev. A* **51**, R1727 (1995).
- Gottesman, D. & Chuang, I. L. Demonstrating the viability of universal quantum computation using teleportation and single-qubit operations. *Nature* **402**, 390–393 (1999).
- Ishizaka, S. & Hiroshima, T. Asymptotic teleportation scheme as a universal programmable quantum processor. *Phys. Rev. Lett.* **101**, 240501 (2008).
- Karlsson, A. & Bourennane, M. Quantum teleportation using three-particle entanglement. *Phys. Rev. A* **58**, 4394 (1998).
- van Loock, P. & Braunstein, S. L. Multipartite entanglement for continuous variables: a quantum teleportation network. *Phys. Rev. Lett.* **84**, 3482 (2000).
- Scarani, V., Iblisdir, S., Gisin, N. & Acín, A. Quantum cloning. *Rev. Mod. Phys.* **77**, 1225 (2005).
- Hayashi, A., Hashimoto, T. & Horibe, M. Reexamination of optimal quantum state estimation of pure states. *Phys. Rev. A* **72**, 032325 (2005).
- Bruß, D. & Macchiavello, C. Optimal state estimation for d -dimensional quantum systems. *Phys. Lett. A* **253**, 249–251 (1999).
- Chen, C.-K., Chen, S.-H., Huang, N.-N. & Li, C.-M. Identifying genuine quantum teleportation. *Phys. Rev. A* **104**, 052429 (2021).
- Carvacho, G. et al. Experimental study of nonclassical teleportation beyond average fidelity. *Phys. Rev. Lett.* **121**, 140501 (2018).
- Hu, X.-M. et al. Experimental certification for nonclassical teleportation. *Quantum Eng.* **1**, e13 (2019).
- Lipka-Bartosik, P. & Skrzypczyk, P. Operational advantages provided by nonclassical teleportation. *Phys. Rev. Res.* **2**, 023029 (2020).
- Mozrzykas, M., Studziński, M. & Kopszak, P. Optimal multi-port-based teleportation schemes. *Quantum* **5**, 477 (2021).
- Studziński, M., Mozrzykas, M., Kopszak, P. & Horodecki, M. Efficient multi port-based teleportation schemes. *IEEE Trans. Inf. Theory* **68**, 7892–7912 (2022).
- Mozrzykas, M., Studziński, M., Strelchuk, S. & Horodecki, M. Optimal port-based teleportation. *New J. Phys.* **20**, 053006 (2018).
- Studziński, M., Strelchuk, S., Mozrzykas, M. & Horodecki, M. Port-based teleportation in arbitrary dimension. *Sci. Rep.* **7**, 10871 (2017).
- Pereira, J. L., Banchi, L. & Pirandola, S. Continuous variable port-based teleportation. Preprint at <https://arxiv.org/abs/2302.08522> (2023).
- Achatz, L. et al. Simultaneous transmission of hyper-entanglement in 3 degrees of freedom through a multicore fiber. Preprint at <https://arxiv.org/abs/2208.10777> (2022).

49. Thomas, P., Ruscio, L., Morin, O. & Rempe, G. Efficient generation of entangled multi-photon graph states from a single atom. *Nature* **608**, 677–681 (2022).
50. Conlon, L. O. et al. Approaching optimal entangling collective measurements on quantum computing platforms. *Nat. Phys.* **19**, 351–357 (2023).
51. Hou, Z. et al. Deterministic realization of collective measurements via photonic quantum walks. *Nat. Commun.* **9**, 1414 (2018).
52. Laurenza, R., Lupo, C., Spedalieri, G., Braunstein, S. L. & Pirandola, S. Channel simulation in quantum metrology. *Quantum Meas. Quantum Metrol.* **5**, 1–12 (2018).
53. Pirandola, S., Laurenza, R., Ottaviani, C. & Banchi, L. Fundamental limits of repeaterless quantum communications. *Nat. Commun.* **8**, 15043 (2017).
54. Bennett, C. H., DiVincenzo, D. P. & Smolin, J. A. Capacities of quantum erasure channels. *Phys. Rev. Lett.* **78**, 3217 (1997).
55. Weedbrook, C. et al. Gaussian quantum information. *Rev. Mod. Phys.* **84**, 621 (2012).
56. Laurenza, R. et al. Tight bounds for private communication over bosonic Gaussian channels based on teleportation simulation with optimal finite resources. *Phys. Rev. A* **100**, 042301 (2019).
57. Laurenza, R. & Pirandola, S. General bounds for sender–receiver capacities in multipoint quantum communications. *Phys. Rev. A* **96**, 032318 (2017).
58. Pirandola, S. Capacities of repeater-assisted quantum communications. Preprint at <https://arxiv.org/abs/1601.00966> (2016).
59. Laurenza, R., Walk, N., Eisert, J. & Pirandola, S. Rate limits in quantum networks with lossy repeaters. *Phys. Rev. Res.* **4**, 023158 (2022).
60. Pirandola, S. End-to-end capacities of a quantum communication network. *Commun. Phys.* **2**, 51 (2019).
61. Pirandola, S., Bardhan, B. R., Gehring, T., Weedbrook, C. & Lloyd, S. Advances in photonic quantum sensing. *Nat. Photon.* **12**, 724–733 (2018).
62. Pirandola, S. & Lupo, C. Ultimate precision of adaptive noise estimation. *Phys. Rev. Lett.* **118**, 100502 (2017).
63. Zhou, S. & Jiang, L. Asymptotic theory of quantum channel estimation. *PRX Quantum* **2**, 010343 (2021).
64. Zhuang, Q. & Pirandola, S. Ultimate limits for multiple quantum channel discrimination. *Phys. Rev. Lett.* **125**, 080505 (2020).
65. Pirandola, S., Laurenza, R., Lupo, C. & Pereira, J. L. Fundamental limits to quantum channel discrimination. *npj Quantum Inf.* **5**, 50 (2019).
66. Sedláč, M., Bisio, A. & Ziman, M. Optimal probabilistic storage and retrieval of unitary channels. *Phys. Rev. Lett.* **122**, 170502 (2019).
67. Banchi, L., Pereira, J., Lloyd, S. & Pirandola, S. Convex optimization of programmable quantum computers. *npj Quantum Inf.* **6**, 42 (2020).
68. Kubicki, A. M., Palazuelos, C. & Perez-Garcia, D. Resource quantification for the no-programming theorem. *Phys. Rev. Lett.* **122**, 080505 (2019).
69. Pereira, J., Banchi, L. & Pirandola, S. Characterising port-based teleportation as universal simulator of qubit channels. *J. Phys. A Math. Theor.* **54**, 205301 (2021).
70. Lipka-Bartosik, P. & Skrzypczyk, P. Catalytic quantum teleportation. *Phys. Rev. Lett.* **127**, 080502 (2021).
71. Yoshida, B. & Yao, N. Y. Disentangling scrambling and decoherence via quantum teleportation. *Phys. Rev. X* **9**, 011006 (2019).
72. Schuster, T. et al. Many-body quantum teleportation via operator spreading in the traversable wormhole protocol. *Phys. Rev. X* **12**, 031013 (2022).
73. Chen, M.-C. et al. Directly measuring a multipartite quantum wave function via quantum teleportation. *Phys. Rev. Lett.* **127**, 030402 (2021).
74. Hou, P.-Y. et al. Quantum teleportation from light beams to vibrational states of a macroscopic diamond. *Nat. Commun.* **7**, 11736 (2016).
75. Sun, K. et al. Experimental quantum entanglement and teleportation by tuning remote spatial indistinguishability of independent photons. *Opt. Lett.* **45**, 6410–6413 (2020).
76. Li, J.-Y. et al. Activating hidden teleportation power: theory and experiment. *Phys. Rev. Res.* **3**, 023045 (2021).
77. Kwiat, P. G. et al. New high-intensity source of polarization-entangled photon pairs. *Phys. Rev. Lett.* **75**, 4337 (1995).
78. Wang, F. et al. Generation of the complete four-dimensional Bell basis. *Optica* **4**, 1462–1467 (2017).
79. Martin, A. et al. Quantifying photonic high-dimensional entanglement. *Phys. Rev. Lett.* **118**, 110501 (2017).
80. Wang, J. et al. Multidimensional quantum entanglement with large-scale integrated optics. *Science* **360**, 285–291 (2018).
81. Kues, M. et al. On-chip generation of high-dimensional entangled quantum states and their coherent control. *Nature* **546**, 622–626 (2017).
82. Lütkenhaus, N., Calsamiglia, J. & Suominen, K.-A. Bell measurements for teleportation. *Phys. Rev. A* **59**, 3295 (1999).
83. Vaidman, L. & Yorán, N. Methods for reliable teleportation. *Phys. Rev. A* **59**, 116 (1999).
84. Schuck, C., Huber, G., Kurtsiefer, C. & Weinfurter, H. Complete deterministic linear optics Bell state analysis. *Phys. Rev. Lett.* **96**, 190501 (2006).
85. Sheng, Y.-B., Deng, F.-G. & Long, G. L. Complete hyperentangled-Bell-state analysis for quantum communication. *Phys. Rev. A* **82**, 032318 (2010).
86. Williams, B. P., Sadler, R. J. & Humble, T. S. Superdense coding over optical fiber links with complete Bell-state measurements. *Phys. Rev. Lett.* **118**, 050501 (2017).
87. Kim, Y.-H., Kulik, S. P. & Shih, Y. Quantum teleportation of a polarization state with a complete Bell state measurement. *Phys. Rev. Lett.* **86**, 1370 (2001).
88. Grice, W. P. Arbitrarily complete Bell-state measurement using only linear optical elements. *Phys. Rev. A* **84**, 042331 (2011).
89. Ewert, F. & van Loock, P. 3/4-Efficient Bell measurement with passive linear optics and unentangled ancillae. *Phys. Rev. Lett.* **113**, 140403 (2014).
90. Ewert, F., Bergmann, M. & van Loock, P. Ultrafast long-distance quantum communication with static linear optics. *Phys. Rev. Lett.* **117**, 210501 (2016).
91. Schmidt, F. & van Loock, P. Efficiencies of logical Bell measurements on Calderbank–Shor–Steane codes with static linear optics. *Phys. Rev. A* **99**, 062308 (2019).
92. Bayerbach, M. J., D’Aurelio, S. E., van Loock, P. & Barz, S. Bell-state measurement exceeding 50% success probability with linear optics. Preprint at <https://arxiv.org/abs/2208.02271> (2022).
93. Graham, T. M., Bernstein, H. J., Wei, T.-C., Junge, M. & Kwiat, P. G. Superdense teleportation using hyperentangled photons. *Nat. Commun.* **6**, 7185 (2015).
94. Chapman, J. C., Graham, T. M., Zeitler, C. K., Bernstein, H. J. & Kwiat, P. G. Time-bin and polarization superdense teleportation for space applications. *Phys. Rev. Appl.* **14**, 014044 (2020).
95. Ru, S. et al. Quantum state transfer between two photons with polarization and orbital angular momentum via quantum teleportation technology. *Phys. Rev. A* **103**, 052404 (2021).
96. Knill, E., Laflamme, R. & Milburn, G. J. A scheme for efficient quantum computation with linear optics. *Nature* **409**, 46–52 (2001).
97. Wei, T.-C., Barreiro, J. T. & Kwiat, P. G. Hyperentangled Bell-state analysis. *Phys. Rev. A* **75**, 060305 (2007).
98. Luo, M.-X., Li, H.-R., Lai, H. & Wang, X. Teleportation of a ququart system using hyperentangled photons assisted by atomic-ensemble memories. *Phys. Rev. A* **93**, 012332 (2016).
99. Choi, S., Lee, S.-H. & Jeong, H. Teleportation of a multiphoton qubit using hybrid entanglement with a loss-tolerant carrier qubit. *Phys. Rev. A* **102**, 012424 (2020).
100. Friis, N., Vitagliano, G., Malik, M. & Huber, M. Entanglement certification from theory to experiment. *Nat. Rev. Phys.* **1**, 72–87 (2019).
101. Barreiro, J. T., Langford, N. K., Peters, N. A. & Kwiat, P. G. Generation of hyperentangled photon pairs. *Phys. Rev. Lett.* **95**, 260501 (2005).
102. Ecker, S. et al. Experimental single-copy entanglement distillation. *Phys. Rev. Lett.* **127**, 040506 (2021).
103. Xie, Z. et al. Harnessing high-dimensional hyperentanglement through a biphoton frequency comb. *Nat. Photon.* **9**, 536–542 (2015).
104. Kim, J.-H. et al. Noise-resistant quantum communications using hyperentanglement. *Optica* **8**, 1524–1531 (2021).
105. Hu, X.-M. et al. Long-distance entanglement purification for quantum communication. *Phys. Rev. Lett.* **126**, 010503 (2021).
106. Steinlechner, F. et al. Distribution of high-dimensional entanglement via an intra-city free-space link. *Nat. Commun.* **8**, 15971 (2017).
107. Cervera-Lierta, A., Krenn, M., Aspuru-Guzik, A. & Galda, A. Experimental high-dimensional Greenberger–Horne–Zeilinger entanglement with superconducting transmon qubits. *Phys. Rev. Appl.* **17**, 024062 (2022).
108. Ringbauer, M. et al. A universal qudit quantum processor with trapped ions. *Nat. Phys.* **18**, 1053–1057 (2022).
109. Fu, Y. et al. Experimental investigation of quantum correlations in a two-qutrit spin system. *Phys. Rev. Lett.* **129**, 100501 (2022).
110. Ding, Y. et al. High-dimensional quantum key distribution based on multicore fiber using silicon photonic integrated circuits. *npj Quantum Inf.* **3**, 25 (2017).
111. Hu, X.-M. et al. Beating the channel capacity limit for superdense coding with entangled ququarts. *Sci. Adv.* **4**, eaat9304 (2018).
112. Wang, T.-J., Yang, G.-Q. & Wang, C. Control power of high-dimensional controlled teleportation. *Phys. Rev. A* **101**, 012323 (2020).
113. Cerf, N. J., Bourennane, M., Karlsson, A. & Gisin, N. Security of quantum key distribution using d -level systems. *Phys. Rev. Lett.* **88**, 127902 (2002).
114. Ecker, S. et al. Overcoming noise in entanglement distribution. *Phys. Rev. X* **9**, 041042 (2019).
115. Hu, X.-M. et al. Pathways for entanglement-based quantum communication in the face of high noise. *Phys. Rev. Lett.* **127**, 110505 (2021).
116. Neeley, M. et al. Emulation of a quantum spin with a superconducting phase qudit. *Science* **325**, 722–725 (2009).
117. Lanyon, B. P. et al. Simplifying quantum logic using higher-dimensional Hilbert spaces. *Nat. Phys.* **5**, 134–140 (2009).
118. Collins, D., Gisin, N., Linden, N., Massar, S. & Popescu, S. Bell inequalities for arbitrarily high-dimensional systems. *Phys. Rev. Lett.* **88**, 040404 (2002).
119. Hu, X.-M. et al. Efficient distribution of high-dimensional entanglement through 11 km fiber. *Optica* **7**, 738–743 (2020).
120. Calsamiglia, J. Generalized measurements by linear elements. *Phys. Rev. A* **65**, 030301 (2002).
121. Zhang, Y. et al. Simultaneous entanglement swapping of multiple orbital angular momentum states of light. *Nat. Commun.* **8**, 632 (2017).
122. Ivonovic, I. Geometrical description of quantal state determination. *J. Phys. A Math. Gen.* **14**, 3241 (1981).
123. Walborn, S. P., Monken, C., Pádua, S. & Ribeiro, P. S. Spatial correlations in parametric down-conversion. *Phys. Rep.* **495**, 87–139 (2010).
124. Qiu, X., Guo, H. & Chen, L. Quantum teleportation of high-dimensional spatial modes: towards an image teleporter. Preprint at <https://arxiv.org/abs/2112.03764> (2021).
125. Sephton, B. et al. High-dimensional spatial teleportation enabled by nonlinear optics. Preprint at <https://arxiv.org/abs/2111.13624v1> (2021).

126. Chen, L. Quantum discord of thermal two-photon orbital angular momentum state: mimicking teleportation to transmit an image. *Light Sci. Appl.* **10**, 148 (2021).
127. Lundeen, J. S., Sutherland, B., Patel, A., Stewart, C. & Bamber, C. Direct measurement of the quantum wavefunction. *Nature* **474**, 188–191 (2011).
128. Cao, H. et al. Distribution of high-dimensional orbital angular momentum entanglement over a 1 km few-mode fiber. *Optica* **7**, 232–237 (2020).
129. Ikuta, T. & Takesue, H. Four-dimensional entanglement distribution over 100 km. *Sci. Rep.* **8**, 817 (2018).
130. Erhard, M., Fickler, R., Krenn, M. & Zeilinger, A. Twisted photons: new quantum perspectives in high dimensions. *Light Sci. Appl.* **7**, 17146 (2018).
131. Pu, Y. et al. Experimental realization of a multiplexed quantum memory with 225 individually accessible memory cells. *Nat. Commun.* **8**, 15359 (2017).
132. Dąbrowski, M. et al. Certification of high-dimensional entanglement and Einstein–Podolsky–Rosen steering with cold atomic quantum memory. *Phys. Rev. A* **98**, 042126 (2018).
133. Tiranov, A. et al. Quantification of multidimensional entanglement stored in a crystal. *Phys. Rev. A* **96**, 040303 (2017).
134. Zhou, Z.-Q. et al. Quantum storage of three-dimensional orbital-angular-momentum entanglement in a crystal. *Phys. Rev. Lett.* **115**, 070502 (2015).
135. Li, C. et al. Quantum communication between multiplexed atomic quantum memories. *Phys. Rev. Lett.* **124**, 240504 (2020).
136. Bacco, D., Bulmer, J. F., Erhard, M., Huber, M. & Paesani, S. Proposal for practical multidimensional quantum networks. *Phys. Rev. A* **104**, 052618 (2021).
137. Braunstein, S. L. & Van Loock, P. Quantum information with continuous variables. *Rev. Mod. Phys.* **77**, 513 (2005).
138. Furusawa, A. et al. Unconditional quantum teleportation. *Science* **282**, 706–709 (1998).
139. Sherson, J. F. et al. Quantum teleportation between light and matter. *Nature* **443**, 557–560 (2006).
140. Krauter, H. et al. Deterministic quantum teleportation between distant atomic objects. *Nat. Phys.* **9**, 400–404 (2013).
141. Liuzzo-Scorpo, P., Mari, A., Giovannetti, V. & Adesso, G. Optimal continuous variable quantum teleportation with limited resources. *Phys. Rev. Lett.* **119**, 120503 (2017).
142. He, Q., Rosales-Zarate, L., Adesso, G. & Reid, M. D. Secure continuous variable teleportation and Einstein–Podolsky–Rosen steering. *Phys. Rev. Lett.* **115**, 180502 (2015).
143. Lie, S. H. & Jeong, H. Limitations of teleporting a qubit via a two-mode squeezed state. *Photonics Res.* **7**, A7–A13 (2019).
144. Tserkis, S., Dias, J. & Ralph, T. C. Simulation of Gaussian channels via teleportation and error correction of Gaussian states. *Phys. Rev. A* **98**, 052335 (2018).
145. Dias, J. & Ralph, T. C. Quantum repeaters using continuous-variable teleportation. *Phys. Rev. A* **95**, 022312 (2017).
146. Borregaard, J., Gehring, T., Neergaard-Nielsen, J. S. & Andersen, U. L. Super sensitivity and super resolution with quantum teleportation. *npj Quantum Inf.* **5**, 16 (2019).
147. Liu, S., Lou, Y. & Jing, J. Orbital angular momentum multiplexed deterministic all-optical quantum teleportation. *Nat. Commun.* **11**, 3875 (2020).
148. Liu, S., Lou, Y., Chen, Y. & Jing, J. All-optical entanglement swapping. *Phys. Rev. Lett.* **128**, 060503 (2022).
149. Wu, Y. et al. Multi-channel multiplexing quantum teleportation based on the entangled sideband modes. *Photonics Res.* **10**, 1909–1914 (2022).
150. Andersen, U. L., Neergaard-Nielsen, J. S., Van Loock, P. & Furusawa, A. Hybrid discrete-and continuous-variable quantum information. *Nat. Phys.* **11**, 713–719 (2015).
151. Brask, J. B., Rigas, I., Polzik, E. S., Andersen, U. L. & Sørensen, A. S. Hybrid long-distance entanglement distribution protocol. *Phys. Rev. Lett.* **105**, 160501 (2010).
152. Takeda, S., Fuwa, M., van Loock, P. & Furusawa, A. Entanglement swapping between discrete and continuous variables. *Phys. Rev. Lett.* **114**, 100501 (2015).
153. Ulanov, A. E., Sychev, D., Pushkina, A. A., Fedorov, I. A. & Lvovsky, A. Quantum teleportation between discrete and continuous encodings of an optical qubit. *Phys. Rev. Lett.* **118**, 160501 (2017).
154. Guccione, G. et al. Connecting heterogeneous quantum networks by hybrid entanglement swapping. *Sci. Adv.* **6**, eaba4508 (2020).
155. Sychev, D. V. et al. Entanglement and teleportation between polarization and wave-like encodings of an optical qubit. *Nat. Commun.* **9**, 3672 (2018).
156. Lvovsky, A. I., Sanders, B. C. & Tittel, W. Optical quantum memory. *Nat. Photon.* **3**, 706–714 (2009).
157. Yu, Y. et al. Entanglement of two quantum memories via fibres over dozens of kilometres. *Nature* **578**, 240–245 (2020).
158. van Leent, T. et al. Entangling single atoms over 33 km telecom fibre. *Nature* **607**, 69–73 (2022).
159. Nadlinger, D. et al. Experimental quantum key distribution certified by Bell’s theorem. *Nature* **607**, 682–686 (2022).
160. Liu, X. et al. Heralded entanglement distribution between two absorptive quantum memories. *Nature* **594**, 41–45 (2021).
161. Lago-Rivera, D., Grandi, S., Rakonjac, J. V., Seri, A. & de Riedmatten, H. Telecom-heralded entanglement between multimode solid-state quantum memories. *Nature* **594**, 37–40 (2021).
162. Humphreys, P. C. et al. Deterministic delivery of remote entanglement on a quantum network. *Nature* **558**, 268–273 (2018).
163. Azuma, K. et al. Quantum repeaters: from quantum networks to the quantum internet. Preprint at <https://arxiv.org/abs/2212.10820> (2022).
164. Sangouard, N., Simon, C., De Riedmatten, H. & Gisin, N. Quantum repeaters based on atomic ensembles and linear optics. *Rev. Mod. Phys.* **83**, 33 (2011).
165. Munro, W. J., Azuma, K., Tamaki, K. & Nemoto, K. Inside quantum repeaters. *IEEE J. Sel. Top. Quantum Electron.* **21**, 78–90 (2015).
166. Wei, S.-H. et al. Towards real-world quantum networks: a review. *Laser Photonics Rev.* **16**, 2100219 (2022).
167. Barasiński, A., Černoč, A. & Lemr, K. Demonstration of controlled quantum teleportation for discrete variables on linear optical devices. *Phys. Rev. Lett.* **122**, 170501 (2019).
168. Lee, S. M., Lee, S.-W., Jeong, H. & Park, H. S. Quantum teleportation of shared quantum secret. *Phys. Rev. Lett.* **124**, 060501 (2020).
169. Awschalom, D. et al. Development of quantum interconnects (quics) for next-generation information technologies. *PRX Quant.* **2**, 017002 (2021).
170. Pan, J.-W. et al. Multiphoton entanglement and interferometry. *Rev. Mod. Phys.* **84**, 777 (2012).
171. Yang, T. et al. Experimental synchronization of independent entangled photon sources. *Phys. Rev. Lett.* **96**, 110501 (2006).
172. Kaltenbaek, R., Blauensteiner, B., Żukowski, M., Aspelmeyer, M. & Zeilinger, A. Experimental interference of independent photons. *Phys. Rev. Lett.* **96**, 240502 (2006).
173. Lo, H.-K., Ma, X. & Chen, K. Decoy state quantum key distribution. *Phys. Rev. Lett.* **94**, 230504 (2005).
174. Reindl, M. et al. All-photon quantum teleportation using on-demand solid-state quantum emitters. *Sci. Adv.* **4**, eaau1255 (2018).
175. Basso Basset, F. et al. Quantum teleportation with imperfect quantum dots. *npj Quantum Inf.* **7**, 7 (2021).
176. Anderson, M. et al. Quantum teleportation using highly coherent emission from telecom c-band quantum dots. *npj Quantum Inf.* **6**, 14 (2020).
177. Anderson, M. et al. Gigahertz-clocked teleportation of time-bin qubits with a quantum dot in the telecommunication c band. *Phys. Rev. Appl.* **13**, 054052 (2020).
178. Sun, Q.-C. et al. Entanglement swapping over 100 km optical fiber with independent entangled photon-pair sources. *Optica* **4**, 1214–1218 (2017).
179. Takesue, H. et al. Quantum teleportation over 100 km of fiber using highly efficient superconducting nanowire single-photon detectors. *Optica* **2**, 832–835 (2015).
180. Valivarthi, R. et al. Teleportation systems toward a quantum internet. *PRX Quantum* **1**, 020317 (2020).
181. Shen, S. et al. Hertz-rate metropolitan quantum teleportation. Preprint at <https://arxiv.org/abs/2303.13866> (2022).
182. Huo, M. et al. Deterministic quantum teleportation through fiber channels. *Sci. Adv.* **4**, eaas9401 (2018).
183. Liu, Z.-D. et al. Efficient quantum teleportation under noise with hybrid entanglement and reverse decoherence. Preprint at <https://arxiv.org/abs/2210.14935> (2022).
184. Fortes, R. & Rigolin, G. Fighting noise with noise in realistic quantum teleportation. *Phys. Rev. A* **92**, 012338 (2015).
185. Yin, J. et al. Quantum teleportation and entanglement distribution over 100-kilometre free-space channels. *Nature* **488**, 185–188 (2012).
186. Ma, X.-S. et al. Quantum teleportation over 143 kilometres using active feed-forward. *Nature* **489**, 269–273 (2012).
187. Kimble, H. J. The quantum internet. *Nature* **453**, 1023–1030 (2008).
188. Hammerer, K., Sørensen, A. S. & Polzik, E. S. Quantum interface between light and atomic ensembles. *Rev. Mod. Phys.* **82**, 1041 (2010).
189. Lu, C.-Y., Cao, Y., Peng, C.-Z. & Pan, J.-W. Micius quantum experiments in space. *Rev. Mod. Phys.* **94**, 035001 (2022).
190. Jennewein, T. et al. Qeyssat: a mission proposal for a quantum receiver in space. In *Advances in Photonics of Quantum Computing, Memory, and Communication VII*, Vol. 8997, 21–27 (SPIE, 2014).
191. Oi, D. K. et al. Cubesat quantum communications mission. *EPJ Quantum Technol.* **4**, 6 (2017).
192. Chen, L.-K. et al. Observation of ten-photon entanglement using thin BiB3O6 crystals. *Optica* **4**, 77–83 (2017).
193. Zuo, Z., Wang, Y., Liao, Q. & Guo, Y. Overcoming the uplink limit of satellite-based quantum communication with deterministic quantum teleportation. *Phys. Rev. A* **104**, 022615 (2021).
194. Chen, Y.-A. et al. An integrated space-to-ground quantum communication network over 4600 kilometres. *Nature* **589**, 214–219 (2021).
195. O’Brien, J. L., Furusawa, A. & Vučković, J. Photonic quantum technologies. *Nat. Photon.* **3**, 687–695 (2009).
196. Wang, J., Sciarino, F., Laing, A. & Thompson, M. G. Integrated photonic quantum technologies. *Nat. Photon.* **14**, 273–284 (2020).
197. Pelucchi, E. et al. The potential and global outlook of integrated photonics for quantum technologies. *Nat. Rev. Phys.* **4**, 194–208 (2022).
198. Vigiari, C. et al. Error-protected qubits in a silicon photonic chip. *Nat. Phys.* **17**, 1137–1143 (2021).
199. Zhang, M. et al. Generation of multiphoton quantum states on silicon. *Light Sci. Appl.* **8**, 41 (2019).
200. Metcalfe, B. J. et al. Quantum teleportation on a photonic chip. *Nat. Photon.* **8**, 770–774 (2014).
201. Taballione, C. et al. 8×8 Reconfigurable quantum photonic processor based on silicon nitride waveguides. *Opt. Express* **27**, 26842–26857 (2019).
202. Zhang, H. et al. Resource-efficient high-dimensional subspace teleportation with a quantum autoencoder. *Sci. Adv.* **8**, eabn9783 (2022).

203. Chan, J. et al. Laser cooling of a nanomechanical oscillator into its quantum ground state. *Nature* **478**, 89–92 (2011).
204. Fiaschi, N. et al. Optomechanical quantum teleportation. *Nat. Photon.* **15**, 817–821 (2021).
205. Lago-Rivera, D., Rakonjac, J. V., Grandi, S. & de Riedmatten, H. Long-distance multiplexed quantum teleportation from a telecom photon to a solid-state qubit. Preprint at <https://arxiv.org/abs/2209.06249> (2022).
206. Zhu, T.-X. et al. On-demand integrated quantum memory for polarization qubits. *Phys. Rev. Lett.* **128**, 180501 (2022).
207. Seri, A. et al. Laser-written integrated platform for quantum storage of heralded single photons. *Optica* **5**, 934–941 (2018).
208. Kindem, J. M. et al. Control and single-shot readout of an ion embedded in a nanophotonic cavity. *Nature* **580**, 201–204 (2020).
209. Raussendorf, R. & Briegel, H. J. A one-way quantum computer. *Phys. Rev. Lett.* **86**, 5188 (2001).
210. Gross, D. & Eisert, J. Novel schemes for measurement-based quantum computation. *Phys. Rev. Lett.* **98**, 220503 (2007).
211. Eisert, J., Jacobs, K., Papadopoulos, P. & Plenio, M. B. Optimal local implementation of nonlocal quantum gates. *Phys. Rev. A* **62**, 052317 (2000).
212. Huang, Y.-F., Ren, X.-F., Zhang, Y.-S., Duan, L.-M. & Guo, G.-C. Experimental teleportation of a quantum controlled-not gate. *Phys. Rev. Lett.* **93**, 240501 (2004).
213. Gao, W.-B. et al. Teleportation-based realization of an optical quantum two-qubit entangling gate. *Proc. Natl Acad. Sci. USA* **107**, 20869–20874 (2010).
214. Ewert, F. & van Loock, P. Teleportation-assisted optical controlled-sign gates. *Phys. Rev. A* **99**, 032333 (2019).
215. Qiao, H. et al. Conditional teleportation of quantum-dot spin states. *Nat. Commun.* **11**, 3022 (2020).
216. Kojima, Y. et al. Probabilistic teleportation of a quantum dot spin qubit. *npj Quantum Inf.* **7**, 68 (2021).
217. Shor, P. W. Fault-tolerant quantum computation. In *Proceedings of 37th Conference on Foundations of Computer Science* 56–65 (IEEE, 1996).
218. Terhal, B. M. Quantum error correction for quantum memories. *Rev. Mod. Phys.* **87**, 307 (2015).
219. Reagor, M. et al. Quantum memory with millisecond coherence in circuit QED. *Phys. Rev. B* **94**, 014506 (2016).
220. Fedorov, K. G. et al. Experimental quantum teleportation of propagating microwaves. *Sci. Adv.* **7**, eabk0891 (2021).
221. Zhong, Y. et al. Violating Bell's inequality with remotely connected superconducting qubits. *Nat. Phys.* **15**, 741–744 (2019).
222. Yan, H. et al. Entanglement purification and protection in a superconducting quantum network. *Phys. Rev. Lett.* **128**, 080504 (2022).
223. Wu, J., Cui, C., Fan, L. & Zhuang, Q. Deterministic microwave-optical transduction based on quantum teleportation. *Phys. Rev. Appl.* **16**, 064044 (2021).
224. Ning, W. et al. Deterministic entanglement swapping in a superconducting circuit. *Phys. Rev. Lett.* **123**, 060502 (2019).
225. Krutyanskiy, V. et al. Entanglement of trapped-ion qubits separated by 230 meters. Preprint at <https://arxiv.org/abs/2208.14907> (2022).
226. Walther, H., Varcoe, B. T., Englert, B.-G. & Becker, T. Cavity quantum electrodynamics. *Rep. Prog. Phys.* **69**, 1325 (2006).
227. Langenfeld, S. et al. Quantum teleportation between remote qubit memories with only a single photon as a resource. *Phys. Rev. Lett.* **126**, 130502 (2021).
228. Kandel, Y. P. et al. Coherent spin-state transfer via Heisenberg exchange. *Nature* **573**, 553–557 (2019).
229. Bernien, H. et al. Heralded entanglement between solid-state qubits separated by three metres. *Nature* **497**, 86–90 (2013).
230. Jing, B. et al. Entanglement of three quantum memories via interference of three single photons. *Nat. Photon.* **13**, 210–213 (2019).
231. Pompili, M. et al. Realization of a multinode quantum network of remote solid-state qubits. *Science* **372**, 259–264 (2021).
232. Walshe, B. W., Baragiola, B. Q., Alexander, R. N. & Menicucci, N. C. Continuous-variable gate teleportation and bosonic-code error correction. *Phys. Rev. A* **102**, 062411 (2020).
233. Luo, Y.-H. et al. Quantum teleportation of physical qubits into logical code spaces. *Proc. Natl Acad. Sci. USA* **118**, e2026250118 (2021).
234. Nielsen, M. A. & Chuang, I. *Quantum Computation and Quantum Information* Ch. 10 (Cambridge Univ. Press, 2002).
235. Huang, H.-L. et al. Emulating quantum teleportation of a Majorana zero mode qubit. *Phys. Rev. Lett.* **126**, 090502 (2021).
236. Sarma, S. D., Freedman, M. & Nayak, C. Majorana zero modes and topological quantum computation. *npj Quantum Inf.* **1**, 15001 (2015).
237. Olivo, A. & Grosshans, F. Ancilla-assisted linear optical Bell measurements and their optimality. *Phys. Rev. A* **98**, 042323 (2018).
238. Aktas, D. et al. Entanglement distribution over 150 km in wavelength division multiplexed channels for quantum cryptography. *Laser Photonics Rev.* **10**, 451–457 (2016).
239. Zhong, H.-S. et al. 12-Photon entanglement and scalable scattershot boson sampling with optimal entangled-photon pairs from parametric down-conversion. *Phys. Rev. Lett.* **121**, 250505 (2018).
240. Qiu, X., Li, F., Liu, H., Chen, X. & Chen, L. Optical vortex copier and regenerator in the Fourier domain. *Photonics Res.* **6**, 641–646 (2018).
241. Schimpf, C. et al. Quantum dots as potential sources of strongly entangled photons: perspectives and challenges for applications in quantum networks. *Appl. Phys. Lett.* **118**, 100502 (2021).
242. Kaneda, F. & Kwiat, P. G. High-efficiency single-photon generation via large-scale active time multiplexing. *Sci. Adv.* **5**, eaaw8586 (2019).
243. Lu, J. et al. Ultralow-threshold thin-film lithium niobate optical parametric oscillator. *Optica* **8**, 539–544 (2021).
244. Goss, N. et al. High-fidelity qutrit entangling gates for superconducting circuits. Preprint at <https://arxiv.org/abs/2206.07216> (2022).
245. Riebe, M. et al. Deterministic entanglement swapping with an ion-trap quantum computer. *Nat. Phys.* **4**, 839–842 (2008).
246. Duan, L.-M., Lukin, M. D., Cirac, J. I. & Zoller, P. Long-distance quantum communication with atomic ensembles and linear optics. *Nature* **414**, 413–418 (2001).
247. van Leent, T. et al. Long-distance distribution of atom-photon entanglement at telecom wavelength. *Phys. Rev. Lett.* **124**, 010510 (2020).
248. Luo, X.-Y. et al. Postselected entanglement between two atomic ensembles separated by 12.5 km. *Phys. Rev. Lett.* **129**, 050503 (2022).
249. Gong, M. et al. Quantum walks on a programmable two-dimensional 62-qubit superconducting processor. *Science* **372**, 948–952 (2021).
250. Kielpinski, D., Monroe, C. & Wineland, D. J. Architecture for a large-scale ion-trap quantum computer. *Nature* **417**, 709–711 (2002).
251. Schäfer, F., Fukuhara, T., Sugawa, S., Takasu, Y. & Takahashi, Y. Tools for quantum simulation with ultracold atoms in optical lattices. *Nat. Rev. Phys.* **2**, 411–425 (2020).
252. Ebadi, S. et al. Quantum phases of matter on a 256-atom programmable quantum simulator. *Nature* **595**, 227–232 (2021).
253. Chen, L. et al. Planar-integrated magneto-optical trap. *Phys. Rev. Appl.* **17**, 034031 (2022).
254. Yao, R. et al. Experimental realization of a multiqubit quantum memory in a 218-ion chain. *Phys. Rev. A* **106**, 062617 (2022).
255. Rakonjac, J. V. et al. Entanglement between a telecom photon and an on-demand multimode solid-state quantum memory. *Phys. Rev. Lett.* **127**, 210502 (2021).
256. Sakr, H. et al. Hollow core optical fibres with comparable attenuation to silica fibres between 600 and 1100 nm. *Nat. Commun.* **11**, 6030 (2020).

Acknowledgements

This work was supported by the National Key Research and Development Program of China (No. 2021YFE0113100), NSFC (Nos 11874345, 11821404, 11904357, 12174367 and 12204458), the Innovation Program for Quantum Science and Technology (No. 2021ZD0301200), the Fundamental Research Funds for the Central Universities, USTC Tang Scholarship, Science and Technological Fund of Anhui Province for Outstanding Youth (2008085J02), China Postdoctoral Science Foundation (2021M700138) and China Postdoctoral for Innovative Talents (BX2021289). This work was partially supported by the USTC Center for Micro and Nanoscale Research and Fabrication.

Author contributions

X.-M.H. wrote the manuscript with the help of Y.G. and B.-H.L. B.-H.L., C.-F.L. and G.-C.G. supervised the research. All authors discussed the content extensively.

Competing interests

The authors declare no competing interests.

Additional information

Peer review information *Nature Reviews Physics* thanks the anonymous reviewers for their contribution to the peer review of this work.

Publisher's note Springer Nature remains neutral with regard to jurisdictional claims in published maps and institutional affiliations.

Springer Nature or its licensor (e.g. a society or other partner) holds exclusive rights to this article under a publishing agreement with the author(s) or other rightsholder(s); author self-archiving of the accepted manuscript version of this article is solely governed by the terms of such publishing agreement and applicable law.

© Springer Nature Limited 2023

Reproduced with permission of copyright owner. Further reproduction prohibited without permission.